



Handling Systems

# Ergonomic Vacuum Lifters

[WWW.SCHMALZ.COM/VACUUM-LIFTERS](http://WWW.SCHMALZ.COM/VACUUM-LIFTERS)

# Schmalz: Vacuum Technology for Intelligent Automation and Ergonomic Handling

**1800**  
**employees**  
working hard for our customers.

**31**  
**locations**  
for outstanding customer service worldwide.

**9**  
**percent**  
of our revenue is invested in innovative ideas and new products.

**590**  
**copyrights**  
are proof of our groundbreaking innovations.



## **Schmalz is one of the Market Leaders in Vacuum Automation and Ergonomic Handling Systems.**

The wide range of products in the Vacuum Automation unit includes individual components such as suction cups and vacuum generators, as well as complete gripping systems and clamping solutions for holding workpieces, for example in CNC machining centers. The Handling Systems unit offers innovative handling solutions with vacuum lifters and crane systems for industrial and handicraft applications.

Our products are used in different applications for example in the logistics industry, the automotive industry, the electronics sector and in furniture production.

With comprehensive consulting, a focus on innovation and first-class quality, Schmalz offers its customers long-lasting benefits. Schmalz's intelligent solutions make production and logistics processes more flexible and efficient, while also preparing them for the increasing trend toward digitalization.

### Vacuum Automation



Components



Systems



Clamping solutions

### Handling Systems



Vacuum lifters and crane systems

# Schmalz Vacuum Lifters and Crane Systems

## APPLICATIONS



**4** Practical Examples  
Vacuum lifters in selected industries

## PRODUCTS



**12** Tube Lifters Jumbo  
Move goods weighing up to 300 kg quickly and easily

Selection aid: Jumbo or VacuMaster? — p. 50



**28** Lifting Devices VacuMaster  
Move heavy loads weighing up to several tons ergonomically and securely  
Selection aid: Jumbo or VacuMaster? — p. 50



**42** Crane Systems  
Aluminum crane systems and jib cranes that are designed specifically for your handling system

## FROM TASK TO SOLUTION



**48** Select, Service, Contact  
We help you find a solution that allows to work more quickly, more ergonomically, and more efficiently



## AWARDED ERGONOMICS

Schmalz vacuum lifters and crane systems support the back and musculo-skeletal system when lifting light and heavy loads. They reduce strain and help to make the work environment ergonomic. This is confirmed by the independent association Aktion Gesunder Rücken (AGR) e. V. (Campaign for Healthier Backs) with its seal of approval. An overview of all tested Schmalz products can be found at: [www.agr-ev.de](http://www.agr-ev.de)

[WWW.SCHMALZ.COM/ERGONOMICS](http://WWW.SCHMALZ.COM/ERGONOMICS)

- ▶ Vacuum tube lifter JumboFlex for commissioning cardboard boxes of varying sizes and qualities
- ▼ Vacuum tube lifters JumboFlex for handling packages in goods receiving and shipping

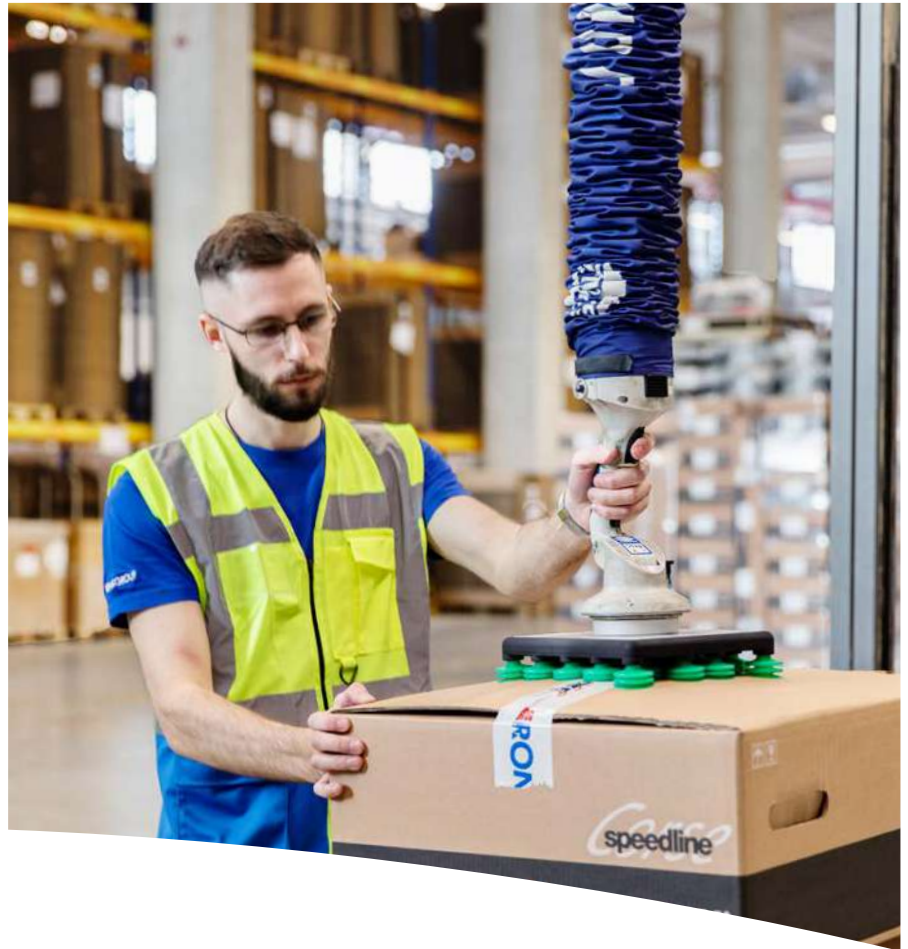

## *The Right Solution for any Task.*

Vacuum handling systems from Schmalz are used in a wide variety of industries to ensure efficient material flows. Our many years of experience and our close relationships with our customers mean we understand your processes, which allows us to produce products to meet the highest standards. They allow loads to be handled faster and more securely while protecting both the materials and your employees. At your request, Schmalz can provide you with a complete workplace solution consisting of a handling system and a crane designed to work perfectly with that system.



Schmalz Media Center  
[WWW.SCHMALZ.COM/VIDEO](http://WWW.SCHMALZ.COM/VIDEO)



## Flexible Handling Solutions for Intra-Logistics and Distribution Logistics

Whether in the goods receiving or shipping area, production logistics or in a parcel distribution center – anywhere goods are moved quickly and frequently, the vacuum tube lifter Jumbo ensures efficient material flows while easing the burden on your employees.



Vacuum tube lifters JumboErgo for lifting cardboard boxes



Vacuum tube lifter JumboFlex Picker for mobile picking of packages with any common industrial truck



Vacuum tube lifter JumboErgo for packaging goods into boxes and handling the sealed boxes



Vacuum tube lifter JumboFlex High-Stack for safe handling of various workpieces at stacking heights of up to 255 cm

## Efficient Machine Loading for all Types of Wooden Boards

The woodworking industry has relied on Schmalz handling systems for decades. They are used in combination with CNC machining centers or panel saws to ensure efficient operation and can fulfill the most demanding requirements, such as turning or swiveling workpieces.



Vacuum tube lifter JumboErgo for loading and unloading a CNC machining center



Vacuum lifting device VacuMaster Comfort for turning coated wooden boards by 180°



Vacuum tube lifter JumboErgo with 90° swivel angle for loading a CNC machining center



Pneumatic vacuum lifting device VacuMaster Wood, 90° swiveling, for transporting wooden boards from the storage to the saw



GLASS

## The Highest Level of Security and Precision

Fragile windows and glass sheets require an especially gentle handling process. Vacuum handling allows a single person to easily move even heavy glass components without the risk of breakage.



Vacuum lifting device VacuMaster Window Comfort for handling windows, glass panes and glass components



Vacuum lifting device VacuMaster Window for vertical handling of glass elements



Vacuum lifting device VacuMaster Window Comfort for loading and unloading a glazing press



Vacuum lifting device VacuMaster Comfort for turning a glass sheet by 180°



## METAL AND SHEET METAL

### Increase Production Efficiency with Effective Machine Loading

Using Schmalz handling systems to load and unload punching machines, bending machines or CNC laser cutting systems reduces downtime while protecting the surface of sensitive workpieces. They can also be used to optimize handling of metal sections and coils.



Vacuum lifting device VacuMaster Basic for loading and unloading a laser cutting machine



Vacuum lifting device VacuMaster Comfort for loading and unloading a laser cutting machine



Vacuum lifting device VacuMaster Coil with 90° swivel angle for handling coils



Vacuum lifting device VacuMaster Eco for energy-independent handling metal parts



## AUTOMOTIVE

### Move Goods Quickly and Easily

In manufacturing workflows manual processes occur such as loading and unloading of presses, handling of boxes and small load carriers in in-house logistics and supplying components to the line. Vacuum lifters relieve operators of the weight of the workpieces, allowing them to work ergonomically.



Vacuum tube lifter JumboFlex for handling windshields



Vacuum tube lifter JumboErgo for handling car body parts



Vacuum tube lifter JumboFlex with rim gripper for handling rims and complete wheels



Vacuum tube lifter JumboFlex Battery for handling batteries



## CHEMICALS AND PHARMACEUTICALS

### Reliable Handling of Goods in Potential Hazard Zones

In the chemical and pharmaceutical industry, safety is of the utmost importance when handling loads. Schmalz products allow bags, barrels, buckets and jugs to be handled smoothly and efficiently. Special solutions are available for explosion protection areas and clean rooms (see page 24).



Vacuum tube lifter JumboSprint Ex for handling bags in an explosion protection zone



Vacuum tube lifter JumboErgo with mechanical gripper for handling jugs



Vacuum tube lifter JumboFlex for palletizing plastic bags



Vacuum tube lifter JumboSprint for handling barrels





## The Right Handling Solution for any Task

Schmalz handling systems ensure efficient material flows in a number of other industries: From universally applicable standard devices to customer-specific solutions, Schmalz is your partner for vacuum handling.



**Beverages** | Vacuum tube lifter JumboErgo with mechanical pneumatic grippers for lifting and turning kegs



**Solar** | Vacuum tube lifter JumboErgo with 90° swivel angle for handling solar panels

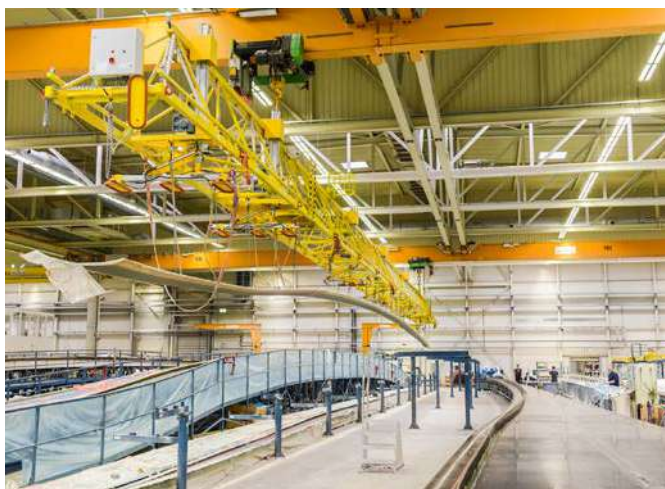

**Wind energy** | Vacuum lifting device VacuMaster for GRP components in rotor blade manufacturing weighing several tons and up to 60 m in length



**Airport** | Vacuum tube lifter JumboFlex for handling of luggage pieces

- ▶ Vacuum tube lifter JumboErgo for packaging goods into boxes
- ▼ Vacuum tube lifter JumboFlex for the order picking of parcels



## *Tube Lifters Jumbo – Great Help for Small Loads.*

Cardboard boxes, bags, barrels, wooden boards and a variety of other applications – the vacuum tube lifter Jumbo tackles big jobs in the shortest amount of time. The intuitive operation allows you to move loads quickly, precisely and always ergonomically. It is the ideal aid for machine loading, for shipping and picking areas and for many other lifting applications.

# Vacuum Tube Lifters Jumbo

Move Goods Weighing up to 300 kg Quickly and Easily

## APPLICATION

- Fast and frequent lifting and moving of workpieces weighing up to 300 kg
- Handling goods such as cardboard boxes, bags, barrels, buckets and jugs within in-house logistics processes
- Loading and unloading CNC machining centers

## PRODUCT HIGHLIGHTS

- Increased productivity thanks to reduced handling and loading times
- Secure, damage-free gripping by using vacuum
- Minimization of downtime due to employee injury
- Increase in employee motivation
- Only one person for handling

## DESIGN AND FUNCTION

The lifting unit, operating unit, vacuum grippers and vacuum generator on the vacuum tube lifter Jumbo can be configured according to customer specifications. The Jumbo is characterized by its lifting unit, which contracts and extends when lifting and lowering the load. The large effective suction area confers a safe holding of the workpiece. Schmalz also offers a comprehensive range of accessories and a complete system with a highly responsive aluminum crane upon request.

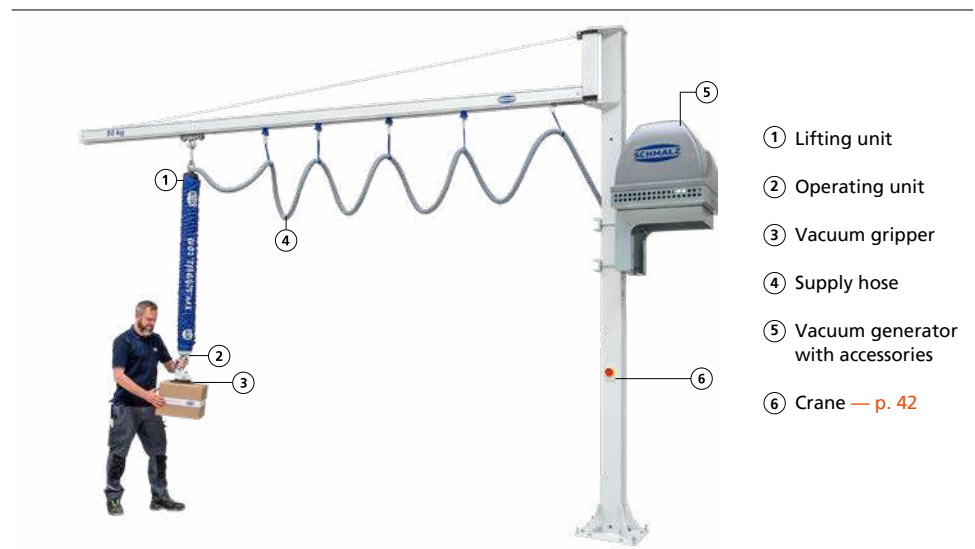

The entire system and its individual parts

## PRODUCT OVERVIEW

JumboFlex, JumboErgo and JumboSprint as well as JumboFlex High-Stack and Jumbo Low-Stack differ in the form and function of their operator handles and are conceived in each case for specific applications.



**JumboFlex**  
One-hand operation for workpieces up to 50 kg  
— p. 14



**JumboErgo**  
For workpieces with different formats up to 300 kg — p. 18



**JumboSprint**  
For compact workpieces up to 300 kg  
— p. 18



**More tube lifters**  
For special applications and industry requirements  
— p. 23

# JumboFlex

Lift Capacity up to 50 kg

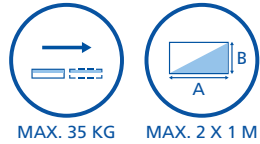

- ① Lifting unit with protective tube
- ② Suspension height can be adjusted without a load attached
- ③ Filter, changeable without tools
- ④ One-finger control for lifting, lowering and releasing the load
- ⑤ Ergonomic control handle with non-slip elements
- ⑥ Continuous rotation, can be locked in 90° increments
- ⑦ Quick-change adapter for fast, tool-free gripper change
- ⑧ Vacuum grippers, adapted to the workpiece
- ⑨ 90° slewing mechanism (manual) for picking up loads from the side
- ⑩ Radio remote control SRC for vacuum generator (optional)

JumboFlex 35

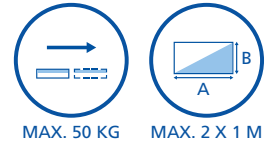
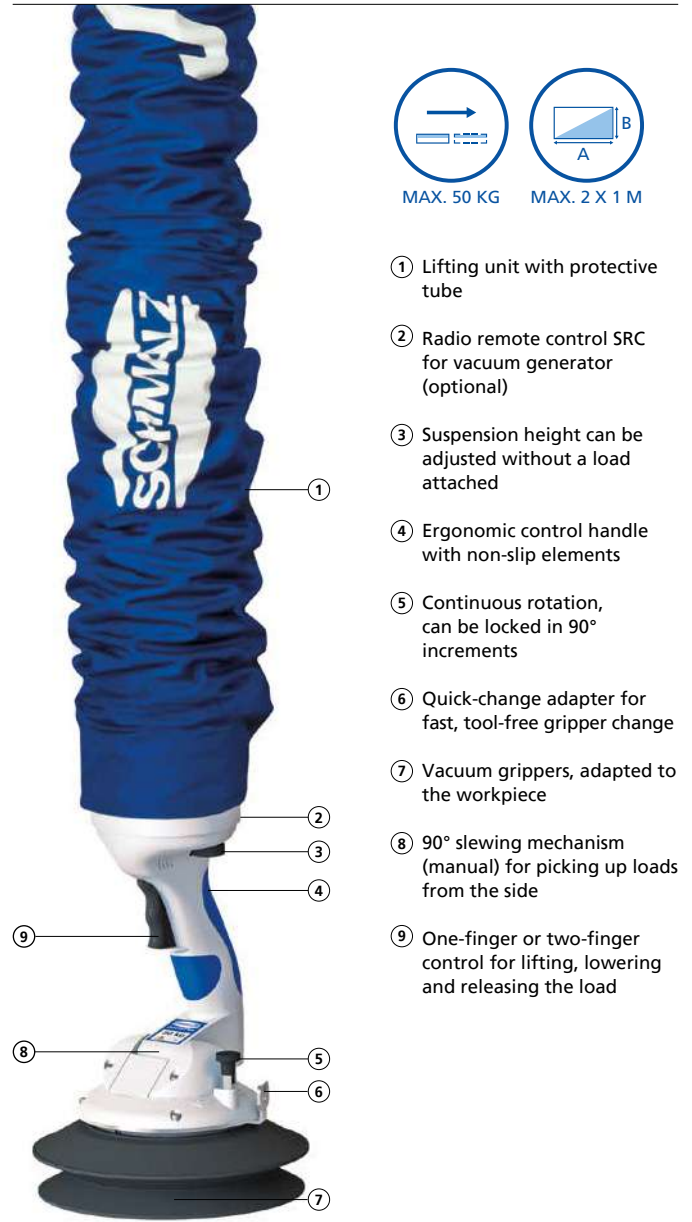

- ① Lifting unit with protective tube
- ② Radio remote control SRC for vacuum generator (optional)
- ③ Suspension height can be adjusted without a load attached
- ④ Ergonomic control handle with non-slip elements
- ⑤ Continuous rotation, can be locked in 90° increments
- ⑥ Quick-change adapter for fast, tool-free gripper change
- ⑦ Vacuum grippers, adapted to the workpiece
- ⑧ 90° slewing mechanism (manual) for picking up loads from the side
- ⑨ One-finger or two-finger control for lifting, lowering and releasing the load

JumboFlex 50

The vacuum tube lifter JumboFlex allows you to move lighter goods up to 50 kg ergonomically and with high cycle rates. The control handle fits comfortably in the hand and allows the operator to work for a long period of time without fatigue. With the simple one-finger control, lifting, lowering and releasing the load is extremely

intuitive. The JumboFlex's wide range of features allows it to tackle virtually any task. It comes standard with a quick-change system for replacing the vacuum grippers. Workpieces which are gripped from the vertical side automatically swing back into the horizontal position where they can be continuously rotated.

**Quick-change adapter  
as standard**



## VACUUM GRIPPERS

Versatility is key: Schmalz offers the correct vacuum grippers for virtually any application. With the quick-change adapter the gripper can be changed quickly and easily.



**Round vacuum gripper**  
For compact goods such as cardboard boxes, barrels, buckets, jugs and cabinets.



**Round vacuum gripper with skirt**  
For optimal sealing on plastic bags and shrink-wrapped packages.



**Double vacuum gripper**  
For stapled, glued, strapped or open cardboard boxes as well as small wooden boards.



**Quadruple vacuum gripper**  
For large cardboard boxes, wooden boards and other flat workpieces.



**Multi gripper**  
Universal gripping of various cardboard box sizes and qualities with a minimum occupancy rate of 75 %.



**2-in-1 gripper**  
Combination of a vacuum gripper and a suspension hook for baggage pieces such as suitcases or bags.



**Suspension hook**  
For mechanical suspension of buckets, jugs and other workpieces with a point from which to hang.



**Box gripper**  
For KLT containers from all common manufacturers. Easy handling thanks to patented centering aid.

## VACUUM GENERATORS



**Pump EVE**  
Electric vacuum generator with short evacuation times and low power consumption.



**Ejector SBPL**  
Basic ejector with maximum suction rate and low compressed air consumption (up to JumboFlex 35).

# JumboFlex

## ADDITIONAL FUNCTIONS



**JumboFlex Safety+**  
Two-hand release for extra safety. Adjustable, reduced lowering speed, e.g. for sensitive components or for disabled users.



**JumboFlex Easy-Release**  
Reduced residual vacuum for easy release. The load is released using an additional release lever and only when fully lowered, e.g. with quadruple grippers or grippers with bellows suction cups.



**JumboFlex Quick-Release**  
Allows loads to be deliberately ejected during lifting by means of an additional ejection lever. For use in baggage handling at airports or similar applications.



**JumboFlex Weight-Control**  
Lifting and weighing of workpieces in just one work step. Optimum process safety thanks to easily adjustable weight limits and visual feedback.

## ACCESSORIES

SRC

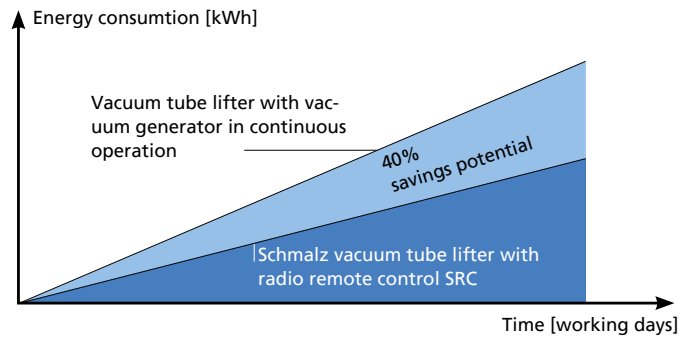

Energy saving potential with SRC radio remote control

### Save up to 40 % energy at the push of a button

With the radio remote control SRC, you can switch the vacuum generator off and on again during work breaks directly at the operating element. The radio remote control requires no external energy (integrated induction generator) and is operated at the push of a button.



### Reduce sound level

The silencer box SBB reduces the sound of the vacuum generator and protects it from external contamination.



### Secure storage

The storage rack AB-JU can be used to store the JumboFlex when not in use in order to protect the lift tube and vacuum grippers.

## TECHNICAL DATA



The vacuum tube lifter JumboFlex can be configured specifically based on the requirements of each individual application due to its modular design. The technical data varies depending on the configuration and on the vacuum gripper chosen.

### Vacuum generator

- Pump with 25, 40, 50 or 67 m<sup>3</sup>/h suction capacity
- Ejector with 52 m<sup>3</sup>/h suction capacity

### Lifting unit

- Max. lifting stroke (Z) 1,500 mm or 1,800 mm
- Diameter (D) 80, 100 or 120 mm

### Vacuum gripper

- Height from 50 mm up to 100 mm

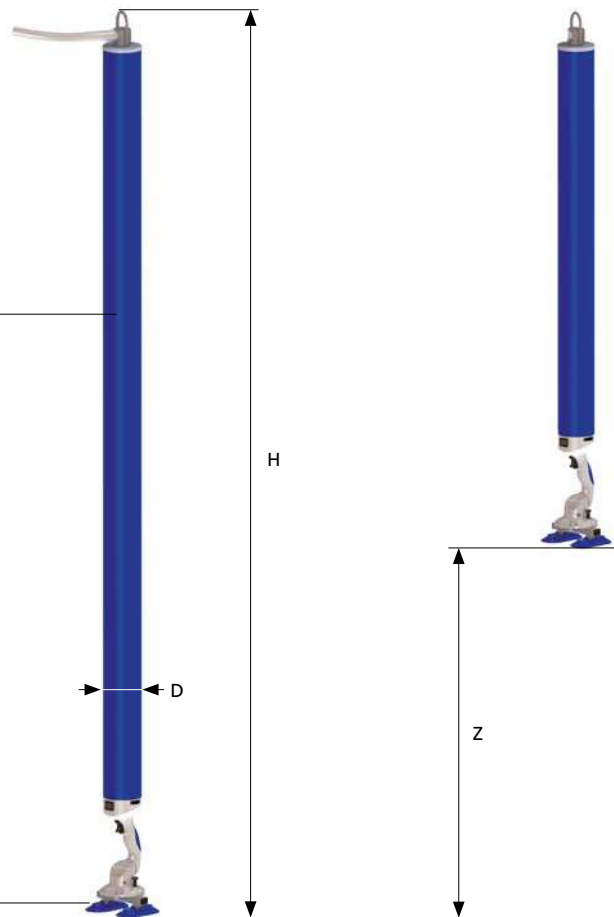

The following technical data are standard values.

Jumbo type	Max. lift capacity [kg]	Workpiece format* [mm]		Max. lifting speed [m/min]	Max. lifting stroke Z [mm]	Height H** [mm]		Lift tube Ø D [mm]
		Minimum	Maximum			With vacuum pump	With vacuum ejector	
Flex 20	20	200 x 200	2,000 x 1,000	60	1,500	2,500	2,680	80
	20	200 x 200	2,000 x 1,000	60	1,800	2,800	2,980	80
Flex 35	35	200 x 200	2,000 x 1,000	60	1,500	2,500	2,680	100
	35	200 x 200	2,000 x 1,000	60	1,800	2,800	2,980	100
Flex 50	50	200 x 200	2,000 x 1,000	60	1,500	2,500	-	120
	50	200 x 200	2,000 x 1,000	60	1,800	2,800	-	120

\*Depends on the vacuum gripper chosen

\*\*Vacuum grippers not included (total height = H + height of the vacuum gripper)

# JumboErgo and JumboSprint

Lift Capacity up to 300 kg

One modular system, two product types: The vacuum tube lifters JumboErgo and JumboSprint share a common technical basis but differ in terms of their operator handles.

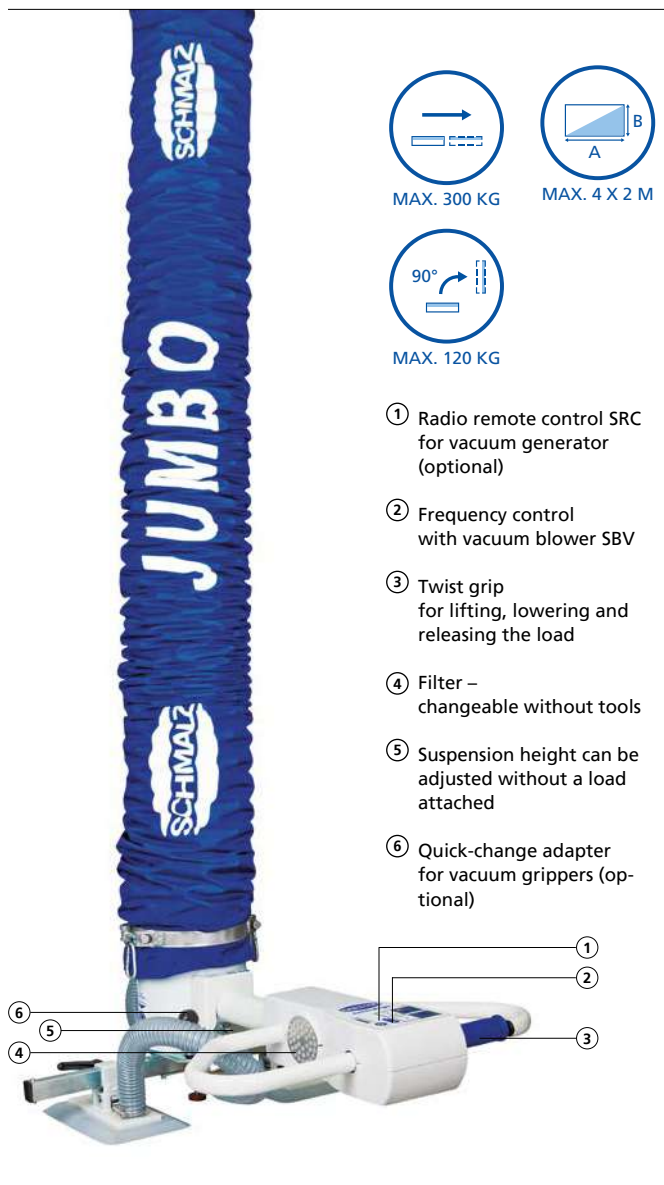

## JUMBOERGO

### For workpieces of many different shapes and sizes

The twist grip on the JumboErgo is designed to operate like a motorcycle throttle. Large and heavy loads such as wooden boards, cardboard boxes and solar panels can be moved gently and precisely. The length of the operator handle can be varied, which allows the user to always maintain a safe distance from the load.



## JUMBOSPRINT

### For compact workpieces

The JumboSprint is equipped with a bow-shaped operator handle which extends all the way around the unit. This allows the user to optimally position it on compact goods such as bags or rubber bails. The load is raised by pulling up on the handle lever and lowered by pushing down.



**Quick-change adapter**  
(optional)

## VACUUM GRIPPERS

Versatility is key: Schmalz offers the right vacuum grippers for virtually any application. With the quick-change adapter the gripper can be changed quickly and easily.



**Single vacuum gripper**  
For compact goods such as cardboard boxes, barrels, buckets, jugs and cabinets.



**Single vacuum gripper, long**  
For pallets, narrow cardboard boxes, beams, square tubes and other elongated workpieces.



**Round vacuum gripper**  
For barrels, buckets or stone slabs with rough surfaces.



**Sack gripper**  
For paper, plastics and fabric bags and porous, bag-like workpieces.



**Double vacuum gripper**  
For cardboard boxes, crates or sheets. The vacuum grippers can be continuously adjusted along the beam.



**Vacuum area gripper FMP**  
For pallets, sections or cut pieces where the vacuum gripper is not fully covered by the workpiece. The grippers can be continuously adjusted along the beam.



**Quadruple vacuum gripper**  
For large cardboard boxes, sheets and non-rigid pieces. The vacuum grippers can be continuously adjusted lengthwise and crossways.



**Multiple vacuum gripper**  
For uneven workpieces such as foil trays or unstable cardboard boxes. The individual vacuum grippers optimally compensate for any unevenness.

## MODULAR GRIPPER SYSTEM



**Modular system for configuring custom grippers**  
In addition to a large number of pre-configured grippers, the modular gripper system adds additional configurations to the Jumbo product range. You can easily configure multiple vacuum grippers that are custom tailored to the respective application.

## VACUUM GENERATORS



**Blowers SBM, SBL, SBV**  
Electric vacuum generators for workpieces up to 300 kg. The frequency controlled blower SBV is continuously variable and its power can be adjusted to changing loads.



**Ejector SEM**  
Compact, compressed air vacuum generator with high flow rate for workpieces weighing up to 85 kg.

# JumboErgo and JumboSprint

## ACCESSORIES



SRC

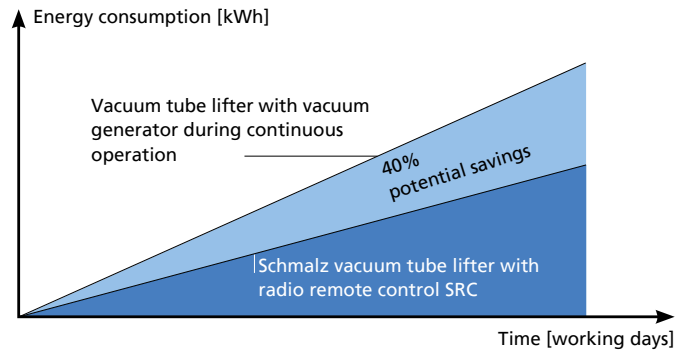

Potential energy savings with radio remote control SRC

**Save up to 40% in energy with the push of a button**  
 With the radio remote control SRC, you can directly switch off the vacuum generator on the operator handle when not in use and then back on again. The radio remote control is activated by a simple button push and needs no energy source due to an integrated solar cell.

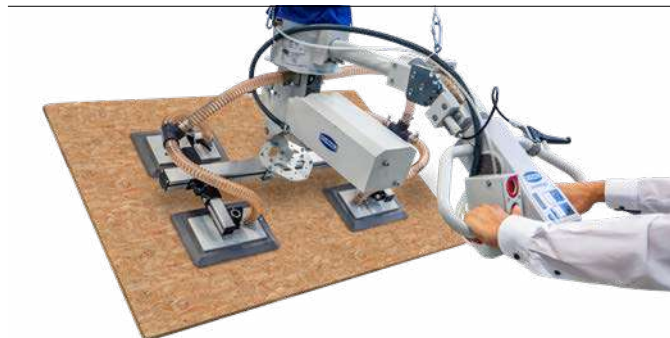

**Swivel workpieces by 90°**  
 With the push of a button, the pneumatic swiveling unit PSE allows the user to swivel workpieces weighing up to 120 kg securely and in an ergonomic fashion.

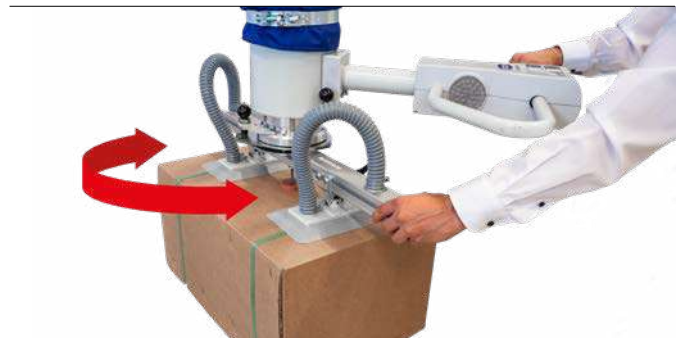

**Continuously rotate workpieces**  
 With the rotation unit DE, gripped workpieces weighing up to 200 kg can be continuously rotated and positioned precisely.



**Maximize stack heights**  
 High stacking heights are no problem with the movable operator handle (only for JumboErgo). An optional locking mechanism allows it to be fixed at different angles.



**Instantly release workpieces**  
 The venting unit BEL allows non-porous workpieces to be released from the vacuum gripper and set down.

## ACCESSORIES



### Reduce the sound level

The silencer box SBB reduces the sound level of the vacuum generator and protects it from outside dirt. It can be easily mounted on the optional blower mounting platform.



### Protection against dirt

The dust filter STF keeps dirt particles away from the vacuum generator and is always recommended to protect the generator. An optional differential pressure monitor with a signal lamp indicates when the dirty filter has to be changed.



### Spring balancer for long operator handles

The spring balancer FZG keeps the tube lifter JumboErgo balanced and is recommended if the operator handle is longer than 750 mm.



### Protection against wear

The protective tube prevents mechanical damage to the lift tube and is easy to clean. The retaining net protects the vacuum grippers and the lift tube when the tube lifter is not in use and allows for space-saving storage.



### Protection against thermal overload

Motor-protection switch MSS for switching on the vacuum and protection against overvoltage.

# JumboErgo and JumboSprint

## Technical Data



The vacuum tube lifters JumboErgo and JumboSprint can be configured specifically based on the requirements of each individual application due to their modular design. The technical data varies depending on the configuration and on the vacuum gripper chosen.

### Vacuum generator

- Blower with 155, 185 or 220 m<sup>3</sup>/h suction capacity
- Ejector with 132 m<sup>3</sup>/h suction capacity

### Lifting unit

- Max. lifting stroke (Z) 1,700 mm or 2,100 mm
- Diameter (D) 120 mm up to 305 mm

### Operator handle

Operator handle length (L)

- JumboErgo: 350 mm up to 1,000 mm
- JumboSprint: 155 mm up to 500 mm

### Vacuum gripper

Height around 80 mm up to 155 mm

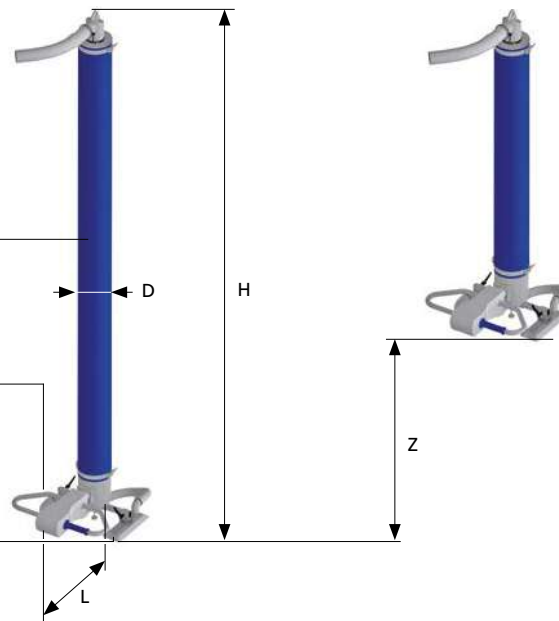
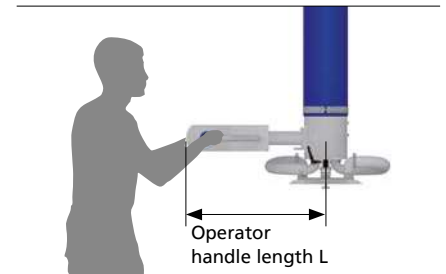

Fig. shows JumboErgo

The following technical data are standard values.

Type	Workpiece format*		Operator handle length L [mm]	Max. lifting speed [m/min]	Max. lifting stroke Z [mm]	Height H** [mm]
	Maximum	Maximum				
JumboErgo	300 x 200	4,000 x 2,000	350 – 1,000	60	1,700	2,850
	300 x 200	4,000 x 2,000				
JumboSprint	300 x 200	3,000 x 1,000	155 – 500	60	1,700	2,850
	300 x 200	3,000 x 1,000				



A lift capacity of 140 kg and higher applies: lifting stroke Z +160 mm, height H +250 mm

\*Depends on the vacuum gripper chosen

\*\*Vacuum gripper not included (total height = H + height of the vacuum gripper)

The operator handle for the JumboErgo is designed with safety in mind, allowing the operator to maintain a safe distance when oversized workpieces are being lifted.

## LIFT CAPACITIES

Jumbo type	Max. lift capacity [kg]		Ø Lift tube D [mm]	Max. lift capacity							
	Horizontal	90° swivel		35 kg	45 kg	65 kg	85 kg	110 kg	140 kg	200 kg	300 kg
Ergo/Sprint 35	35	–	120	→							
Ergo/Sprint 45	45	30	140	→	→						
Ergo/Sprint 65	65	50	160	→	→	→					
Ergo/Sprint 85	85	70	178	→	→	→	→				
Ergo/Sprint 110	110	90	203	→	→	→	→	→			
Ergo/Sprint 140	140	120	230	→	→	→	→	→	→		
Ergo/Sprint 200	200	–	250	→	→	→	→	→	→	→	
Ergo/Sprint 300	300	–	305	→	→	→	→	→	→	→	→





JumboFlex Picker for mobile use in order picking tasks



MAX. 50 KG

## JumboFlex Picker and JumboFlex Mobile

### Mobile Solutions for Changing Locations

#### APPLICATION

- Picking of mixed pallets from unmixed pallets for onward transport
- De-stacking of pallets for distribution to different storage locations or further processing locations

#### JumboFlex Picker

- Mobile handling solution for use in order picking tasks
- Operation via standard 24V battery

#### JumboFlex Mobile

- Transportable handling solution for flexible use in changing locations
- Operation via power connection (400V 50Hz 16A)



Transportable tube lifter solution JumboFlex Mobile for use in changing locations

#### DESIGN AND FUNCTION

- Vacuum tube lifter JumboFlex (1) with a lift capacity of up to 50 kg and a stroke of approx. 1,300 mm
- Height-adjustable column (2) to increase the maximum gripping height to 1,800 mm
- Responsive articulated arm jib (3) with 360° radius of action with approx. 2,400 mm outreach and approx. 1,600 mm moving length
- Visually optimized basic module (4) with control technology, vacuum generation and status LED display
- Forks (5) for one or two pallets in different versions (JumboFlex Picker)

#### PRODUCT HIGHLIGHTS

- Quickly deployable to changing locations
- Ergonomic handling with the tube lifter JumboFlex and responsive articulated arm jib
- Compact transport dimensions due to height-adjustable column and compact parking position of the articulated arm jib
- Low noise level due to sophisticated main body with very good noise insulation

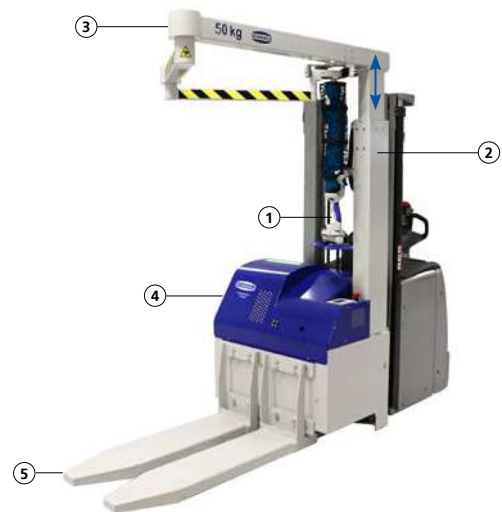

Design JumboFlex Picker



JumboSprint EX for handling bags in an explosion protection zone



## JumboSprint Ex

Safe Handling in an Explosion Protection Zone

### APPLICATION

- Efficient handling of loads weighing up to 250 kg in explosion protection zones
- Lifting of bags, barrels, cardboard boxes, jugs, buckets and varnish/paint containers
- Preparation and positioning of filled bags, e.g. for emptying into hoppers or mixers
- For use in explosion protection zones 1/21 and 2/22
- Certified according to ATEX 2014/34/EU standard – use throughout Europe without country-specific certification

### DESIGN AND FUNCTION

- Vacuum generator (1) – blower or ejector for special Ex version
- Jib crane (2) with steel crane rail
- Vacuum tube lifter JumboSprint EX (3)



Design JumboSprint Ex

### PRODUCT HIGHLIGHTS

- Operator handle and grippers made from stainless steel
- All conductive parts are connected with a potential equalization
- Conductive lift tube made from a special material
- Vacuum generator either compressed air driven (ejector up to 85 kg) or electric (blower up to 250 kg)
- Various vacuum grippers in explosion protection design
- Easily change vacuum grippers using the quick-change adapter (optional)
- Complete system for vacuum tube lifter and steel jib crane for explosion protection zone available

### AREAS OF APPLICATION

Explosion zone	Vacuum generator	Max. lifting stroke [mm]	Max. lift capacity						
			45 kg	65 kg	85 kg	110 kg	140 kg	200 kg	250 kg
1/21	Ejector	1,700 / 2,100	▶	▶	▶				
2/22	Ejector	1,700 / 2,100	▶	▶	▶				
	Blower	1,700 / 2,100	▶	▶	▶	▶	▶	▶	▶



PalVac Sprint Hygienic when handling bags in a hygienic area

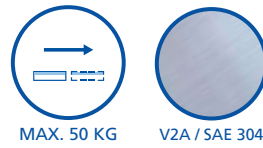

## PalVac Sprint Hygienic

Safe Handling in Clean Rooms and Hygienic Areas

### APPLICATION

- Frequent and fast lifting and moving of workpieces up to 50 kg
- Handling of workpieces such as food products, bags, barrels, buckets, canisters, etc. in clean rooms and hygienic areas
- For processes in the food product, pharmaceutical, biotech, medical and many other industries
- Optimum power transmission when handling compact workpieces such as bags or frozen goods

### DESIGN AND FUNCTION

- Vacuum generation by electrical blower up to 50 kg lift capacity
- Flexible vacuum supply hose
- Lifting unit with wipeable protective tube (1) and integrated filter element with clogging indicator (2)
- Operator handle (3) with bow-shaped operator handle for lifting, lowering and releasing the load
- Individually matched vacuum gripper (4) for different workpieces

### PRODUCT HIGHLIGHTS

- Increased productivity due to shorter handling and loading times as well as safe and damage-free gripping with vacuum
- Easy and fast cleaning due to tool-free disassembly, wipeable protective tube and resistance to many detergents
- Low build-up of powder/germs due to low-crack and low-gap design and high-quality surface polishing
- Avoidance of environmental contamination and protection of employees through integrated filter elements
- No alteration of the handled goods by using non-reactive, non-crumbling, non-absorbent materials



Design PalVac Sprint Hygienic



PalVac stainless steel jib crane with articulated jib or conventional jib





JumboFlex High-Stack for high stacking of cardboard boxes



## JumboFlex High-Stack

For Optimal Use of Space in Storage Areas and Transport Equipment

### APPLICATION

- Ideal for stacking cardboard boxes and bags in the optimum ergonomic range up to a stacking height of 255 cm
- Ergonomic movement of compact goods up to 50 kg at high cycle frequencies
- Ergonomic movement of various goods to ensure efficient material flows, e.g. in intralogistics applications
- Workpieces near floor height can be handled while maintaining upright posture



JumboFlex High-Stack when handling bags

### DESIGN AND FUNCTION

- Lifting unit (1) with sturdy lifting tube and integrated rotary union for continuous rotation of the tube lifter
- Vacuum generation by means of an electric pump
- Extended ergonomic one-handed control handle (2) with guide bars and a safety feature for releasing the workpiece
- Continuously rotatable vacuum grippers (3) that can be replaced without tools for a wide range of workpieces



Design JumboFlex High-Stack

### PRODUCT HIGHLIGHTS

- Optimal use of space in storage areas and transport equipment
- Best possible ergonomics thanks to configurable handle length and continuously adjustable guide bar
- Integrated vacuum feed for minimum wear and avoidance of interfering contours
- Reduced residual vacuum at the gripper makes it easy to release the workpiece
- Universally applicable with standard quick-change system for replacing the extensive range of gripper accessories



Jumbo Low-Stack for handling raw rubber bales in grid boxes

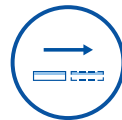

MAX. 80 KG

## Jumbo Low-Stack

Ergonomically Picking up Workpieces from Low Heights

### APPLICATION

- Ideal for picking up and depositing workpieces up to 80 kg from low heights while maintaining upright posture
- Ergonomic handling in low and medium height working areas
- Ergonomic loading and unloading of transport containers, allowing you to reach deeply into grid boxes, crates, and cardboard boxes
- Fast and frequent lifting and moving of crates, bags and other airtight workpieces



Jumbo Low-Stack when handling bags

### DESIGN AND FUNCTION

- Shortened lifting unit (1) with sturdy lifting tube and integrated rotary union for continuous rotation of the tube lifter
- Vacuum generation by electric blower
- Operator handle (2) with lateral twist grip for lifting, lowering and releasing the load and integrated mechanism for adjusting the suspension height without load
- Individually selected vacuum grippers (3) for a wide variety of workpieces



Design Jumbo Low-Stack

### PRODUCT HIGHLIGHTS

- Sustained reduction of back pain by maintaining upright posture while handling at low heights
- Intuitive and reliable operation – the twist grip slides through your hand during the lifting movement without the need to change your grip
- Can be used for a wide range of workpieces and transport containers thanks to the wide range of grippers
- Compact design that is ideal for reaching into narrow containers



▶ Vacuum lifting device  
VacuMaster Basic for handling  
metal sheets

▼ Vacuum lifting device VacuMaster  
Comfort for loading a panel saw



## *Lifting Devices VacuMaster – Lighten Your Load.*

The vacuum lifting device VacuMaster from Schmalz is the ultimate workhorse. Whether handling metal plates, wooden boards, plastic sheets, barrels, windows or glass sheets – the VacuMaster tackles even the heaviest tasks with weights up to several tons. For applications where many hands would normally be required, the VacuMaster allows workpieces to be handled effortlessly by just a single operator while protecting the employee's health.

# Vacuum Lifting Devices VacuMaster

Move Heavy Loads Weighing up to Several Tons Ergonomically

## APPLICATION

- For handling large, flat and typically non-porous workpieces
- Loading and unloading CNC laser cutting machines with metal plates
- Loading and unloading CNC machining centers with wooden boards or plastic sheets
- Handling and positioning glass panels and windows during production, framing and installation

## PRODUCT HIGHLIGHTS

- Efficient, non-damaging handling of heavy loads
- To work ergonomically and protect operator health
- Excellent work safety and process reliability thanks to vacuum reservoir and audible warning device
- Long service life due to a robust mixture of steel, aluminum and high-strength plastic
- Low operating costs thanks to controlled vacuum generator with energy saving (Comfort version)

## DESIGN AND FUNCTION

The vacuum lifting device VacuMaster has a modular design. Various basic modules, operator handles, load beams and suction plates allow you to customize the configuration. The necessary suction force is generated by the vacuum generator and transferred to the workpiece via the suction plates. For safety purposes, the aluminum load beam also serves as a vacuum reservoir. A chain hoist is required for lifting or lowering motion.

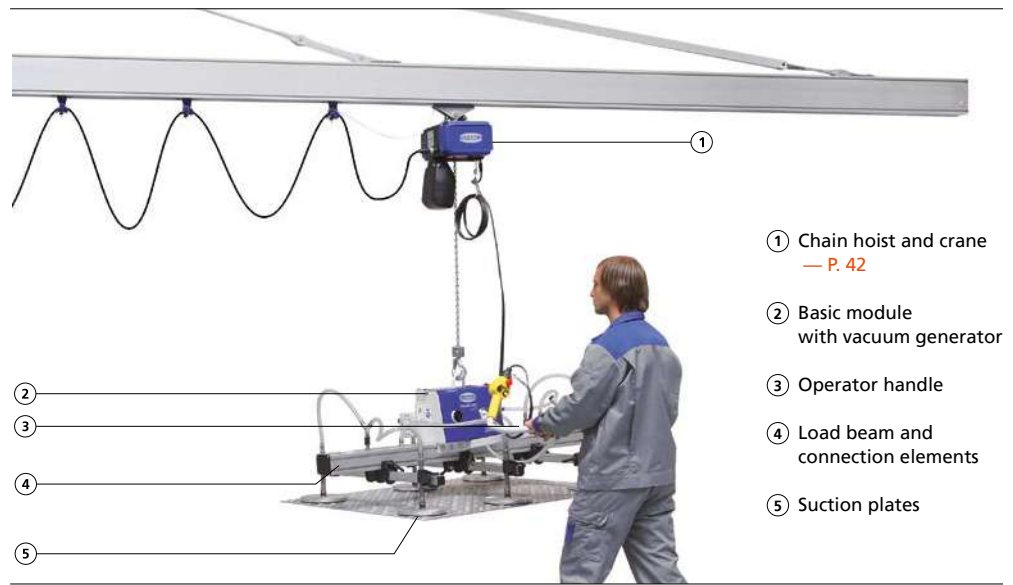

The entire system and its individual parts

## PRODUCT OVERVIEW

The right solution for any task: With their modular system, VacuMaster Basic and VacuMaster Comfort cover standard applications weighing up to 750 kg.

Type	Max. lift capacity						
	100 kg	125 kg	250 kg	500 kg	1,000 kg	1,500 kg	2,000 kg
VacuMaster Horizontal	✓	✓	✓	✓	✓	✓	✓
VacuMaster 90° Swiveling	✓	✓	✓	✓	✓	✓	✓
VacuMaster 180° Turning	✓	✓	✓	✓	✓	✓	✓

--- Additional lift capacities up to more tons on request



**VacuMaster Basic and VacuMaster Comfort**  
Flexible modular system for standard applications weighing up to 750 kg  
— P. 30



**Additional VacuMaster**  
For special lift capacities and industry requirements  
— P. 36

# VacuMaster Basic and VacuMaster Comfort

Lift Capacity up to 750 kg

The VacuMaster Basic's versatile standard equipment makes it indispensable for many applications. In addition, the VacuMaster Comfort offers an operator handle that brings together all of the device's controls as well as a controlled vacuum generator for reducing energy consumption.



MAX. 750 KG

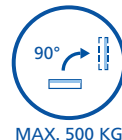

MAX. 500 KG



MAX. 250 KG



MAX. 8 X 2 M

## VACUMASTER BASIC



- ① Motor protection switch
- ② Vacuum gauge (manometer)
- ③ Vacuum on/off – picks up and releases the load via a highly reliable manual slide valve
- ④ Operator handle – Schmalz chain hoist pendant can be attached
- ⑤ Chain hoist up/down – lifts and lowers the load
- ⑥ Emergency-stop function for chain hoist

## VACUMASTER COMFORT



- ① Vacuum gauge (manometer)
- ② Integrated air-saving function
- ③ Swivel function – continuous swiveling up to max. 90° or 180°
- ④ Vacuum off – secure release of the load requiring two hands
- ⑤ Vacuum on – picks up the load
- ⑥ Emergency-stop function
- ⑦ Operator handle with integrated function modules for Schmalz chain hoist
- ⑧ Chain hoist up/down – lifts and lowers the load

## BASIC MODULE

The basic module is the heart of every VacuMaster. It contains the vacuum generator, an audible warning device as well as all the measuring and control devices. Depending on the application, you can choose from three different basic modules whose shape and design are optimally suited to the handling task.



### Horizontal handling

Standard design with vacuum generator, audible warning device, vacuum gauge (manometer) and motor protection switch. Protection of the components under a robust sheet metal barrier.

- For lift capacity up to 750 kg



### 90° swiveling

Basic version adds to electric drive for jolt-free, continuous swiveling by 90°.

- For lift capacity up to 500 kg



### 180° turning

Basic version adds to electric drive for jolt-free, continuous turning by 180°.

- For lift capacity up to 250 kg

## VACUUM GENERATORS



### Pump EVE

Electric vacuum generator for smooth and suction-tight workpieces weighing up to 750 kg.



### Ejector SBPL

Basic ejector with highest suction rate and low compressed air consumption.



## MANUAL SLIDE VALVE

### Reliable and safe vacuum control

VacuMaster Basic with manual slide valve for high safety by double actuation and anti-trap protection. Prevents unwanted losing of the load.

## LOAD BEAM AND CONNECTION ELEMENTS



### Light, robust and flexible

The combination of aluminum and high-strength plastic allows the cross beams and suction plates to be easily adjusted to quickly adapt to changing formats.



### Integrated vacuum reservoir

The large vacuum reservoir prevents the load from falling in the case of a power failure and makes gripping faster during repeated lifting processes.

## SUCTION PLATES



### Versatility for every task

Allows for optimal adaptation to the workpiece and to requirements such as heat resistance, food safety and mark-free gripping. Select from suspension which is rigid, spring-mounted or both flexible and spring-mounted.

# VacuMaster Basic and VacuMaster Comfort

## ACCESSORIES



### Maximize stack heights

Large height differences are no problem with the swiveling and locking operator handle. The working posture remains ergonomic in any position.



### Adapts to changing workpieces

With the vacuum gripper shut-off valve several vacuum grippers can be turned off for handling of cut pieces or pieces with gaps.



### Secure storage of the lifting device

When the lifting device is not in use, the parking stands allow it to be stored securely while protecting the suction plates. This allows the crane to be used for other purposes.



### Quick-connect electrical connection

The CEE plug allows the lifting device to be easily connected to the power supply and then quickly disconnected if necessary (only for VacuMaster Basic).



### Mark-free handling

The suction plate covers prevent the plates from leaving marks on sensitive workpieces such as glass sheets or solar panels.



### Protection against water

The water separator reliably prevents water from entering the vacuum generator during moist processes such as water-jet cutting.

## TECHNICAL DATA



Thanks to their modular system, the VacuMaster Basic and VacuMaster Comfort can be custom configured for any application. The technical data of the devices are dependent on the selected configuration. You can use the following data on pre-configured lifting devices for standard workpiece formats as a guide for determining the recommended values for your VacuMaster. **Proceed as Follows:**

**1** Select type of handling  
e.g. horizontal handling

**2** Select lift capacity  
e.g. 250 kg

**3** Select workpiece format  
e.g. 2,000 x 1,000 mm



### HORIZONTAL HANDLING

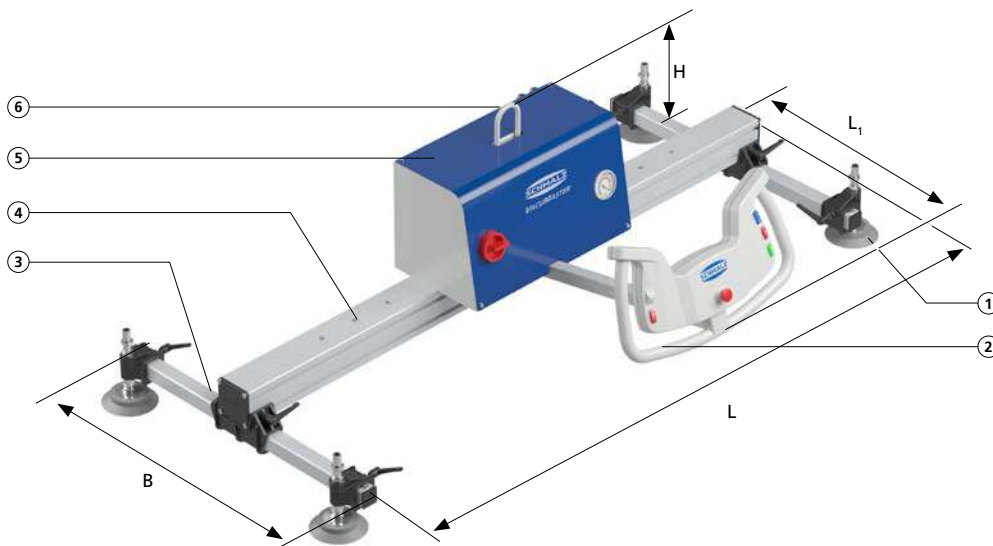

- ① Suction plates, diameter 125 mm up to 360 mm
- ② Operator handle ( $L_1$ ) 345 mm up to 1,060 mm
- ③ Cross beams (B) 400 mm up to 1,500 mm
- ④ Main beam (L) 800 mm up to 6,400 mm
- ⑤ Basic module with vacuum generator, vacuum pump with 4, 8, 16, 25 m<sup>3</sup>/h suction capacity, vacuum ejector with 53,5 m<sup>3</sup>/h suction capacity
- ⑥ Eye for chain hoist, diameter 52 mm

Fig. shows VacuMaster Comfort

VacuMaster type* Max. lift capacity [kg]	Workpiece format [mm]	Dimensions L x B (length x width) [mm]	Overall height H [mm]		Operator handle $L_1$ [mm]	Suction plates**		Weight [kg]	
			Basic	Comfort		No.	Ø [mm]	Basic	Comfort
Basic/Comfort 125	1,000 x 1,000	800 x 750	490	445	655	1	250	38	42
	2,000 x 1,000	1,600 x 750	410	445	645	2	210	42	50
	2,500 x 1,250	1,600 x 750	490	525	745	4	125	52	64
	3,000 x 1,500	2,400 x 1,150	555	590	945	6	125	62	68
	4,000 x 2,000	3,200 x 1,500	555	590	1,045	8	125	80	88
Basic/Comfort 250	1,000 x 1,000	800 x 750	490	445	655	1	360	40	45
	2,000 x 1,000	1,600 x 750	410	445	645	2	250	44	52
	2,500 x 1,250	1,600 x 750	490	525	745	4	210	54	62
	3,000 x 1,500	2,400 x 1,150	555	590	945	6	160	59	67
	4,000 x 2,000	3,200 x 1,500	555	590	1,045	8	125	80	88
Basic/Comfort 500	2,500 x 1,250	1,600 x 750	570	605	760	4	250	71	84
	3,000 x 1,500	2,400 x 1,150	635	670	960	6	210	88	91
	4,000 x 2,000	3,200 x 1,500	635	670	1,060	8	210	106	130
Basic/Comfort 750	3,000 x 1,500	2,400 x 1,150	635	670	960	6	250	91	105
	4,000 x 2,000	3,200 x 1,500	635	670	1,060	8	210	115	122

\*The shown VacuMaster are example configurations: The VacuMaster Basic/Comfort can be adapted flexibly to individual workpiece formats.

\*\*The indicated number of suction plates is possible for handling of rigid goods. For unstable and thin workpieces the numbers of suction plates will be increased.



# VacuMaster Basic and VacuMaster Comfort

## Technical Data

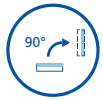

90° SWIVELING

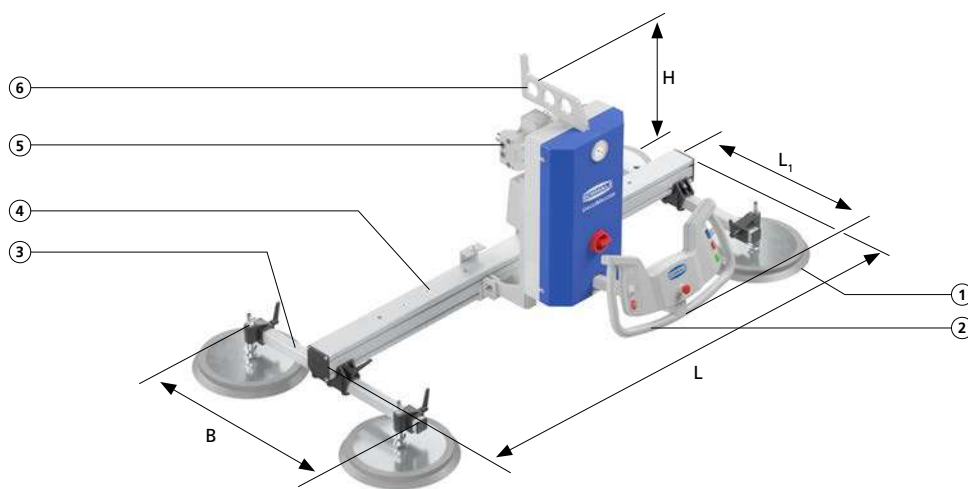

- ① Suction plates – diameter 125 mm up to 360 mm
- ② Operator handle (L<sub>1</sub>) – 425 mm up to 1,185 mm
- ③ Cross beams (B) – 400 mm up to 1,500 mm
- ④ Main beam (L) – 800 mm up to 6,400 mm
- ⑤ Basic module with vacuum generator – vacuum pump with 4, 8, 16, 25 m<sup>3</sup>/h suction capacity
- ⑥ Eye for chain hoist – diameter 50 mm

Fig. shows VacuMaster Comfort

VacuMaster type* Max. lift capacity [kg]	Workpiece format [mm]	Dimensions L x B (length x width) [mm]	Overall height H [mm]		Operator handle L <sub>1</sub> [mm]	Suction plates**		Weight [kg]	
			Basic	Comfort		No.	Ø [mm]	Basic	Comfort
Basic/Comfort 125	2,000 x 1,000	1,600 x 750	720	720	725	2	360	74	76
	2,500 x 1,250	1,600 x 750	800	800	725	4	210	79	81
	4,000 x 2,000	3,200 x 1,500	800	800	1,025	8	210	94	101
Basic/Comfort 250	2,500 x 1,250	1,600 x 750	800	800	725	4	360	91	93
	4,000 x 2,000	3,200 x 1,500	800	800	1,025	8	210	102	104
Basic/Comfort 500	2,500 x 1,250	1,600 x 750	1,030	1,030	785	4	360	135	137
	4,000 x 2,000	3,200 x 1,500	1,030	1,030	1,085	8	360	151	153

\*The shown VacuMaster are example configurations: The VacuMaster Basic/Comfort can be adapted flexibly to individual workpiece formats.

\*\*The indicated number of suction plates is possible for handling of rigid goods. For unstable and thin workpieces the numbers of suction plates will be increased.



## 180° TURNING

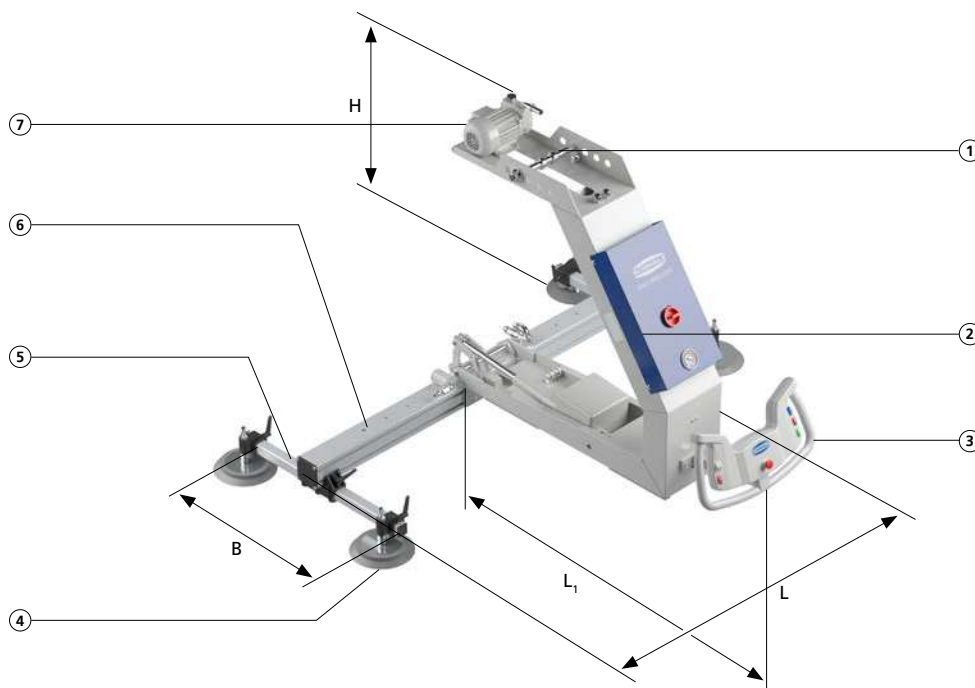

- ① Adjustment possibility to hook the chain hoist – diameter 25 mm
- ② Basic module
- ③ Operator handle ( $L_1$ ) – 1,265 mm up to 1,830 mm
- ④ Suction plates – diameter 125 mm up to 360 mm
- ⑤ Cross beams (B) – 400 mm up to 1,500 mm
- ⑥ Main beam (L) – 800 mm up to 6,400 mm
- ⑦ Vacuum generator – vacuum pump with 4, 8, 16 m<sup>3</sup>/h suction capacity

Fig. shows VacuMaster Comfort

VacuMaster type* Max. lift capacity [kg]	Workpiece format [mm]	Dimensions L x B (length x width) [mm]	Overall height H [mm]		Operator handle $L_1$ [mm]	Suction plates**		Weight [kg]	
			Basic	Comfort		No.	Ø [mm]	Basic	Comfort
Basic/Comfort 75	1,000 x 1,000	800 x 750	1,150	1,150	1,265	2	250	74	74
	2,000 x 1,000	1,600 x 750	1,150	1,150	1,265	2	250	82	82
	2,500 x 1,250	1,600 x 750	1,220	1,220	1,265	4	210	92	92
Basic/Comfort 125	2,000 x 1,000	1,600 x 750	1,160	1,160	1,265	2	360	87	87
	2,500 x 1,250	1,600 x 750	1,230	1,230	1,265	4	210	92	92
Basic/Comfort 250	2,000 x 1,000	1,600 x 750	1,770	1,770	1,830	4	360	137	139
	2,500 x 1,250	1,600 x 750	1,750	1,750	1,830	8	210	145	147
	4,000 x 2,000	3,200 x 1,500	1,750	1,750	1,830	8	210	165	167

\*The shown VacuMaster are example configurations: The VacuMaster Basic/Comfort can be adapted flexibly to individual workpiece formats.

Technical data for VacuMaster Basic/Comfort 500 on request.

\*\*The indicated number of suction plates is possible for handling of rigid goods. For unstable and thin workpieces the numbers of suction plates will be increased.



VacuMaster Vario in process of loading and unloading a laser cutting machine



## VacuMaster Vario

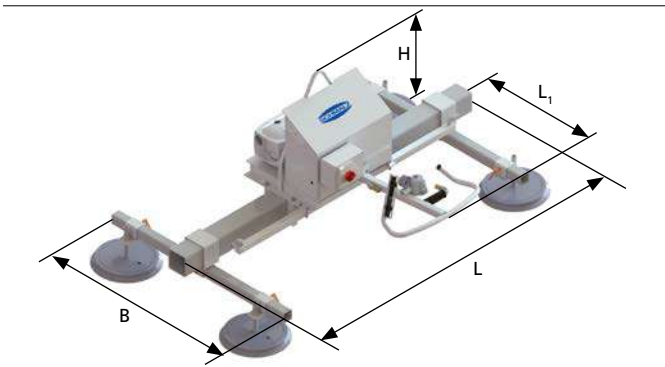

Design of VacuMaster Vario



Special VacuMaster Vario with lift capacity of 10 t  
(special applications with lift capacity over 2 t on request)

### APPLICATION

- Horizontal handling of especially heavy, airtight workpieces weighing up to 2,000 kg
- Loading and unloading machines with large-format metal sheets and plates
- Solutions for heavier loads are also possible, e.g. lifting devices for handling rotor blades weighing several tons and up to 60 m in length

### DESIGN AND FUNCTION

- Modular vacuum lifting device with ergonomic operator handle
- Highly reliable manual slide valve to turn on/off the vacuum
- Electric vacuum pump for short evacuation times
- Robust steel load beam
- Audible warning device and vacuum reservoir for redundant safety in loss of vacuum and power failure respectively
- Large selection of suction plates

### PRODUCT HIGHLIGHTS

- Heavy loads are handled very securely
- Simple adaption to the individual application

VacuMaster type	Max. lift capacity* [kg]	Workpiece format [mm]		Dimensions [mm]		Overall height H [mm]	Operator handle L <sub>1</sub> [mm]	Number of suction plates	Weight [kg]
		Minimum	Maximum	L (length)	B (width)				
Vario 1000	1,000	900 x 520	6,000 x 2,000	2,000 – 4,000	1,150	630 – 935	910 – 1,250	1, 4, 8	116 – 252
Vario 2000	2,000	1,230 x 900	6,000 x 2,000	2,000 – 4,000	1,150	820 – 1,000	910 – 1,250	2, 4, 8	231 – 345

\*Higher lift capacities available on request.



VacuMaster Eco for removing steel sheets from a drawer shelving system



UNIVERSAL

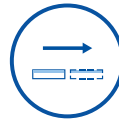

MAX. 1000 KG

## VacuMaster Eco

### APPLICATION

- Horizontal handling of smooth and airtight workpieces without an external energy source
- For example metal sheets/plates, barrels and stone slabs

### DESIGN AND FUNCTION

- Modular vacuum lifting device with piston system for vacuum generation without energy
- Vacuum is established/dissipated by the lifting/lowering motion of the chain hoist (chain hoist not included)
- Aluminum load beam with integrated vacuum distributor (up to 750 kg lift capacity)
- Battery-operated warning device with battery test function for warning of fallen vacuum
- Easily adjustable vacuum grippers

### PRODUCT HIGHLIGHTS

- Secure and gentle vacuum handling
- Energy independence allows for flexibility in use
- Quick installation and start of operations
- Minimal operating costs

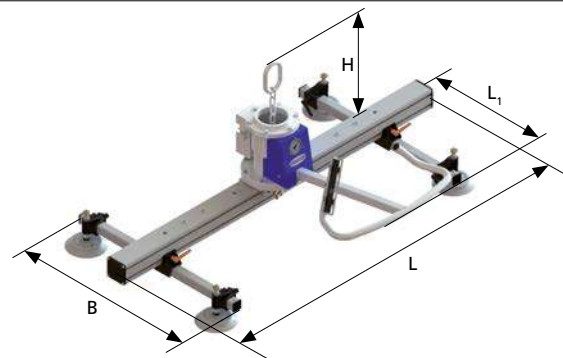

Design of VacuMaster Eco

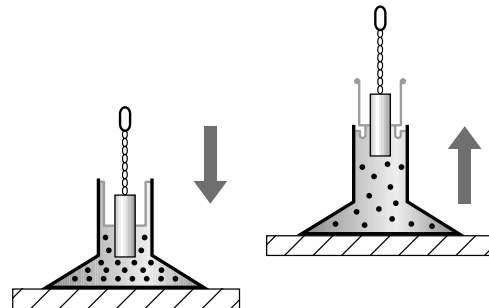

Functional principle of VacuMaster Eco

VacuMaster type	Max. lift capacity* [kg]	Workpiece format [mm]		Dimensions [mm]		Overall height H [mm]	Operator handle L <sub>1</sub> [mm]	Number of suction plates	Weight [kg]
		Minimum	Maximum	L (length)	B (width)				
Eco 75	75	220 x 220	1,000 x 1,000	210	210	368 – 382	–	1	8
Eco 250	250	360 x 360	3,000 x 2,000	800 – 2,400	400 – 1,500	450 – 825	400 – 1,100	1, 2, 4, 6, 8	33 – 59
Eco 500	500	480 x 480	4,000 x 2,000	800 – 3,200	400 – 1,500	605 – 1,130	500 – 1,200	1, 2, 4, 6, 8	93 – 141
Eco 750	750	900 x 620	4,000 x 2,000	800 – 3,200	400 – 1,500	735 – 1,130	500 – 1,200	4, 6, 8	132 – 141
Eco 1000	1,000	630 x 630	4,000 x 2,000	800 – 4,000	1,150	730 – 1,210	500 – 1,200	1, 4, 8	138 – 309

\*The recommended minimum workpiece weight is 10% of the lift capacity.



VacuMaster Window for rotating and palletizing windows



GLASS



MAX. 300 KG

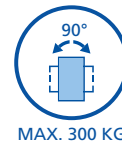

MAX. 300 KG

## VacuMaster Window

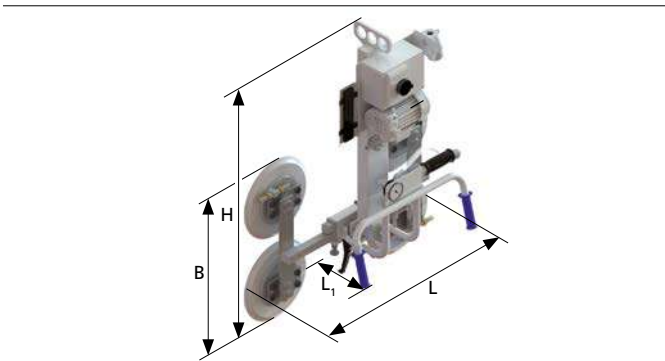

Design of VacuMaster Window

### APPLICATION

- Vertical handling of windows, glass sheets and glass components
- For windows with sash parts or frames protruding up to 45 mm
- Workpieces can be rotated by 90°

### DESIGN AND FUNCTION

- Operator handle with ergonomic bow shape
- Electric vacuum pump for short evacuation times
- Audible warning device and vacuum reservoir for redundant safety in loss of vacuum and power failure respectively
- UV and ozone resistant suction plates
- Manual rotation up to 90° (left/right)
- Electric turning (right) optional for Comfort version
- Comfort operation with integrated control of all functions



VacuMaster Window Comfort

### PRODUCT HIGHLIGHTS

- Secure handling of glass while leaving no marks
- Increase in productivity due to faster turnover
- Effortless rotation of workpieces

VacuMaster type	Max. lift capacity [kg]	Workpiece format [mm]		Dimensions [mm]		Overall height H [mm]	Operator handle L <sub>1</sub> [mm]	Suction plates		Weight [kg]
		Minimum	Maximum	L (length)	B (width)			No.	Ø [mm]	
Window 200	200	320 x 630	2,000 x 2,000	630-930	300	920	390 - 570	2	300	39 - 71
Window 300	300	630 x 630	2,000 x 2,000	630-930	630	1,090	400 - 650	4	300	55 - 76



VacuMaster Wood Comfort for loading a CNC machining center



## VacuMaster Wood

### APPLICATION

- Handling of a wide range of airtight or porous boards up to 250 kg
- Ideal for raw or coated MDF, OSB and chipboard as well as gypsum fiberboards, plasterboards and plastic boards
- Loading and unloading of panel saws and machining centers
- Swiveling of workpieces by up to 90° for removal from upright storages and loading of upright saws

### DESIGN AND FUNCTION

- Basic module incl. multi-stage vacuum ejector "High Flow", audible warning device, vacuum gauge and dust filter
- Operating in Comfort design with ergonomic handle shape and integrated control elements
- Main beam optionally with movable cross beams
- Special suction plates with friction pads for high transverse force absorption

### PRODUCT HIGHLIGHTS

- Energy-saving and low-noise handling of heavy wooden boards by only one person
- Ergonomic handling thanks to low weight and height adjustable operator handle
- High safety due to integrated vacuum reservoir as well as audible and visual warning devices
- Low operating costs thanks to controlled vacuum generator with energy saving function

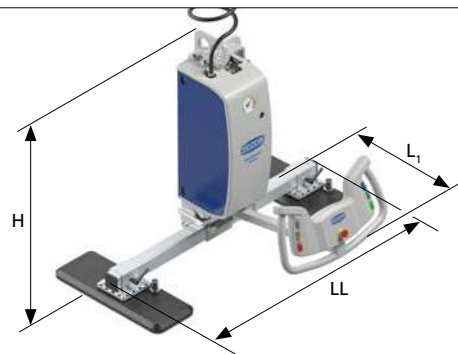

Design VacuMaster Wood

VacuMaster Type	Max. lift capacity [kg]	Workpiece format [mm]		Main beam LL [mm]	Cross beam LQ [mm]	Overall height H [mm]	Operator handle L <sub>1</sub> [mm]	Suction plates		Weight [kg]
		Minimal	Maximal					Number	Size [mm]	
VM Wood C-H-1600-2	250	600 x 560	2,500 x 1,250	1,600	-	860	600	2	200 x 550	62
VM Wood C-H-2400-4	250	800 x 550	4,500 x 2,000	2,400	1,150	860	770	4	180 x 340	90
VM Wood C-90-1600-2	250	600 x 560	2,500 x 1,250	1,600	-	600	600	2	200 x 550	72
VM Wood C-90-2400-4	250	800 x 550	4,500 x 2,000	2,400	1,150	900	770	4	180 x 340	102



VacuMaster Coil for swiveling stainless steel coils by 90°

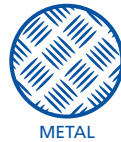

METAL



MAX. 1000 KG

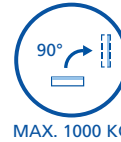

MAX. 1000 KG

## VacuMaster Coil

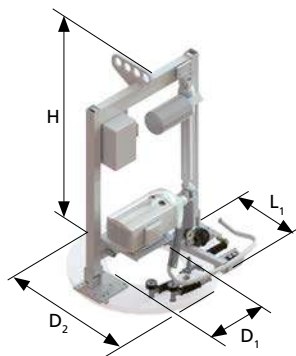

Design of VacuMaster Coil

### APPLICATION

- Handling coils and slit strip, e.g. for positioning onto a decoiler mandrel
- For thin and ultra-thin sheet metal, steel and stainless steel, metal foils, tinplate and aluminum
- Maximum strip thickness of 3.0 mm (aluminum) or 1.5 mm (steel)
- Continuous swiveling up to 90°

### DESIGN AND FUNCTION

- Vacuum lifting device with vacuum clamps (suction rings) that can be switched on/off separately
- Highly reliable manual slide valve for activating vacuum
- Electric vacuum pump for short evacuation times
- Precise electric drive for continuous swiveling of the load
- Audible warning device and vacuum reservoir for redundant safety in loss of vacuum and power failure respectively
- Transparent suction plate for easily positioning



Suction plate with three separate vacuum clamps

### PRODUCT HIGHLIGHTS

- Different sized coils can be handled with one device
- Exact positioning and safe gripping of coils
- Damage-free gripping without mechanical clamping
- Loads can be swiveled effortlessly and set down flush with the floor

VacuMaster type	Max. lift capacity [kg]	Workpiece format Ø [mm]		Max. coil height		Overall height H [mm]	Operator handle L <sub>1</sub> [mm]	Suction plate Ø [mm]		Number of suction clamps	Weight [kg]
		Minimum	Maximum	At 50 Hz	At 60 Hz			Inner D <sub>1</sub>	Outer D <sub>2</sub>		
Coil 500 90°	500	600	1,200	400	330	1,300	660	410	850	3	140
Coil 750 90°	750	600	1,400	220	160	1,300	660	410	1,050	3	155
Coil 1000 90°	1,000	750	1,800	320	240	1,300	660	410	1,200	3	190



VacuMaster Light for handling metal sheets



UNIVERSAL



MAX. 100 KG

## VacuMaster Light

### APPLICATION

- Horizontal handling of mainly airtight small to medium-sized workpieces weighing up to 100 kg
- For example, metal plates, plastic sheets, barrels, cabinets, furniture parts or sections
- Its versatility allows it to be used in processes such as component assembly, packaging and machine loading

### DESIGN AND FUNCTION

- Compact and light vacuum lifting device
- Pneumatic vacuum ejector with high suction capacity
- Operator handle with manual slide valve for vacuum control
- Choose between a large suction plate, four jointed and continuously adjustable suction cups or variable traverse system

### PRODUCT HIGHLIGHTS

- Ergonomic operation and low weight allow you to work for long periods without fatigue
- Vacuum grippers can be adjusted quickly and easily to handle different workpieces
- Quick and easy installation and startup

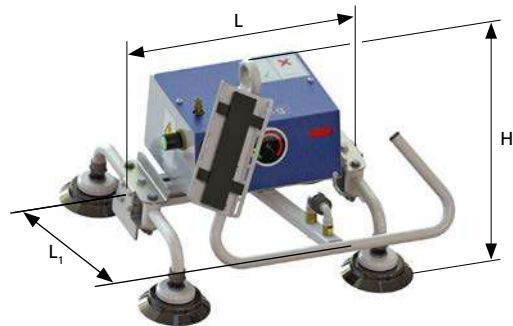

Design of VacuMaster Light

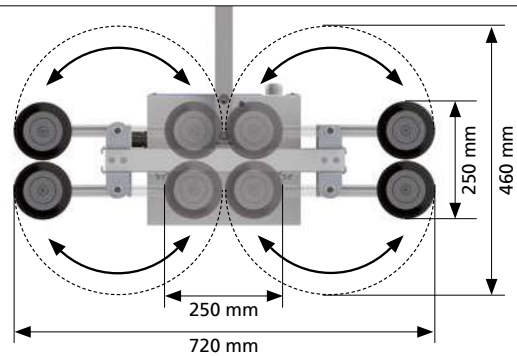

Vacuum gripper spacing with adjustable suction feet (VacuMaster Light 100-4)

VacuMaster type	Max. lift capacity [kg]	Workpiece format [mm]		Length L [mm]	Overall height H [mm]	Operator handle L <sub>1</sub> [mm]	Suction plates		Weight [kg]
		Minimum	Maximum				No.	Ø [mm]	
Light 100-1	100	250 x 250	1,500 x 800	260	270	405	1	250	15
Light 100-4	100	250 x 250	2,000 x 800	400	330	405	4	120	15
Light-CON	100	420 x 310	2.500 x 1.250	500 – 1.600	320 – 410	410 – 650	4 – 6	110 – 250	14 – 30

▶ Aluminum crane system SRA with lifting device VacuMaster mounted on modular crane gantry KBG

▼ Column-mounted jib crane SK with lifting device VacuMaster Basic

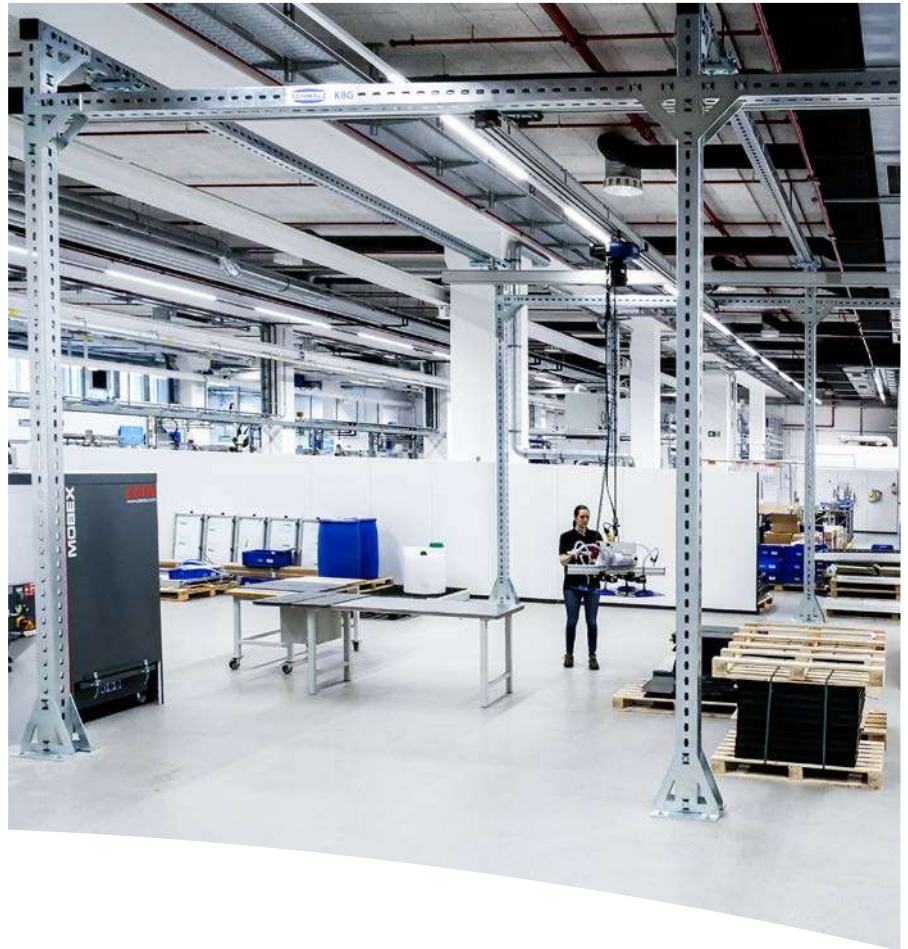

## Crane Systems – The Easy Way.

We have drawn on all of our experience and expertise as system manufacturers to create our Schmalz crane systems. Thanks to their consistently lightweight design, they are the perfect addition to your vacuum tube lifter Jumbo or vacuum lifting device VacuMaster. Whether as a jib crane or a crane system, the Schmalz modular system enables perfect integration into your working environment. Even as a stand-alone solution, the modern crane system provides numerous advantages for your benefit.

# Aluminum Jib Cranes

Lift Capacity up to 1,000 kg



Column-mounted jib crane SK with chain hoist and lifting device VacuMaster



Wall-mounted jib crane WK with tube lifter Jumbo

## APPLICATION

- Workplace crane solution for ergonomic and efficient handling of loads
- Available as a column-mounted or wall-mounted jib crane
- Optimally adjustable to the nominal lift capacity of the tube lifter or lifting device

## PRODUCT HIGHLIGHTS

- Outstanding low-friction operation and low moving mass
- High-quality wear-resistant components and modern design with anodized surfaces
- Speeds up working processes and enables high-precision positioning
- Supports ergonomic operation while reducing strain on workers

## DESIGN AND FUNCTION

### Column-mounted jib crane SK

- Aluminum crane rail and pivot bearing
- Steel crane column, optional with integrated motor-protection switch
- Already fitted with anchors for floor mounting without additional intermediate plates
- Optionally available with a mobile base plate for easy transport using a forklift or pallet truck

### Wall-mounted jib crane WK

- With the same jib boom as the column-mounted jib cranes
- Mounted using a wall bracket or clasp bracket (for example on a building column in a production room)

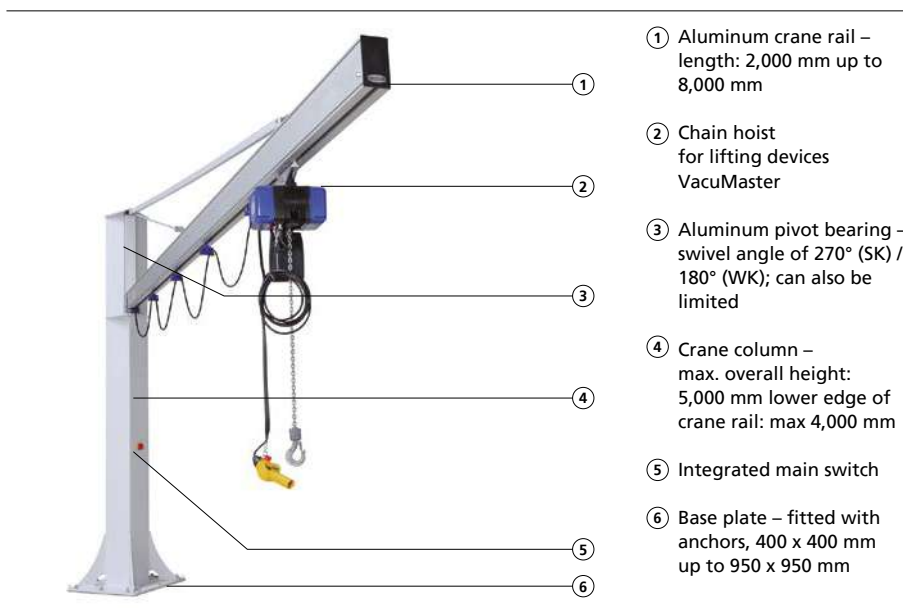

Type	Max. lift capacity											
	45 kg	65 kg	80 kg	85 kg	110 kg	125 kg	140 kg	200 kg	300 kg	350 kg	650 kg	1,000 kg
Jib crane for Jumbo*	[Blue arrow indicating lift capacity range from 45 kg to 300 kg]											
Universal jib crane (for use with chain hoist/VacuMaster)	[Blue arrow indicating lift capacity range from 45 kg to 1,000 kg]											

\*The load classes correspond to the nominal lift capacities of the tube lifter Jumbo. The tube lifter's weight has already been taken into account.

# Aluminum Crane Systems

Lift Capacity up to 1,200 kg



Aluminum crane system SRA with a chain hoist and lifting device VacuMaster



Aluminum crane system SRA with chain hoist and lifting device VacuMaster

## APPLICATION

- Flexible modular system for the assembly of individual crane solutions
- Used in nearly all in-house handling and logistics processes
- Optimally adjustable to the nominal lift capacity of the tube lifter or lifting device

## PRODUCT HIGHLIGHTS

- Outstanding low-friction operation and low moving mass
- High-quality wear-resistant components
- Modern design with anodized surfaces
- Speeds up working processes and enables high-precision positioning
- Supports ergonomic operation while reducing worker strain

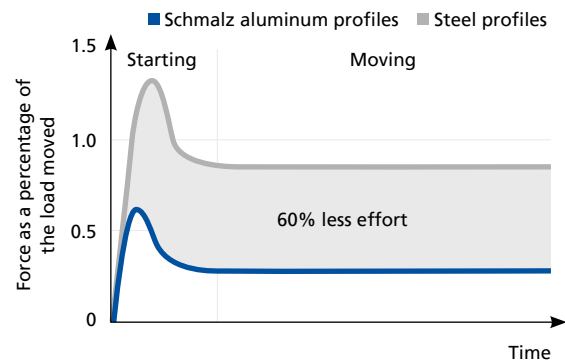

Advantages of aluminum crane systems compared to conventional steel cranes

## DESIGN AND FUNCTION

- Aluminum crane profile SRA extremely resistant to bending and torsion forces
- Can be configured as a single-girder, double-girder or monorail crane system
- Several crane girders (bridges) can be used in one crane system
- Crane runways can be extended as needed using rail connectors; also for existing cranes
- Optimized energy supply
- Easy to install on a ceiling or portal construction using rigid or height-adjustable suspension elements
- Flexible adjustable working area with variable end stops

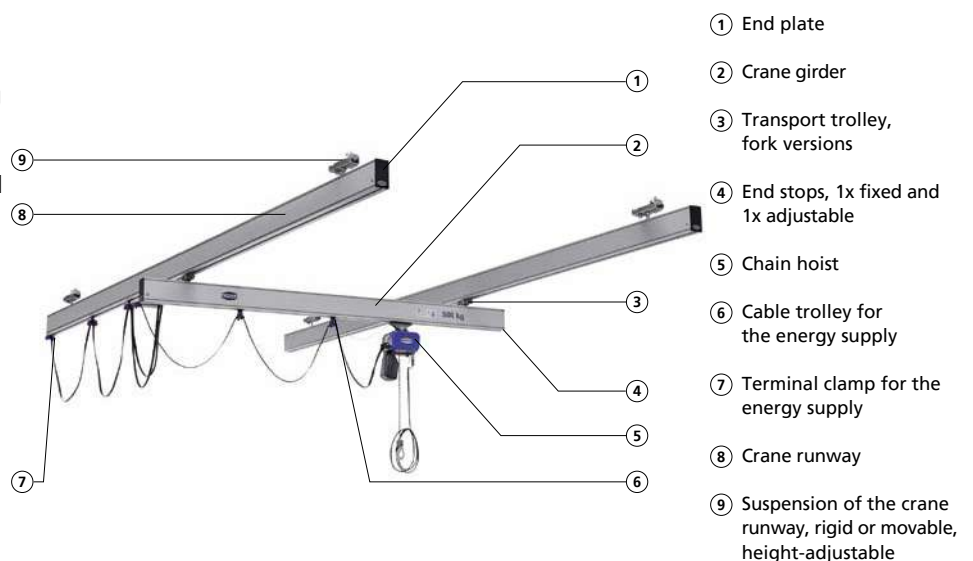

# Modular Steel Construction KBG

## Flexible Connection of the Schmalz Aluminum Overhead Crane System

### APPLICATION

- Available as crane gantry KBG-G and cantilever arm KBG-C
- Setup of individual crane solutions in combination with the Schmalz aluminum overhead crane system SRA if it cannot be suspended from the ceiling
- Any extension of the system in length is possible

### PRODUCT HIGHLIGHTS

- Few components and modular design allow fast processing and short delivery times
- Flexible integration into the existing production layout and easy adaptation and expansion in case of subsequent changes
- Easy installation and mounting thanks to the screw set and the intelligent modular system
- Robust surface protection due to the galvanized profile surface

### DESIGN AND FUNCTION

- Self-developed rolled profile (1), 140 x 140 x 4 mm, with perforations for connecting the connecting plates, grid in steps of 100 mm
- Intelligent connection technology (2) for connecting the components to the profile
- Corner plate (3) for connecting cross and longitudinal beam to the pillar (side beam is required for higher loads)
- T-plate (4) for connecting pillar and side beam
- Base plate (5) for fastening the pillar to the floor by means of dynamic plugs
- Suspension plate (6) for attaching the Schmalz aluminum overhead crane system



Vacuum tube lifter Jumbo mounted on crane gantry KBG

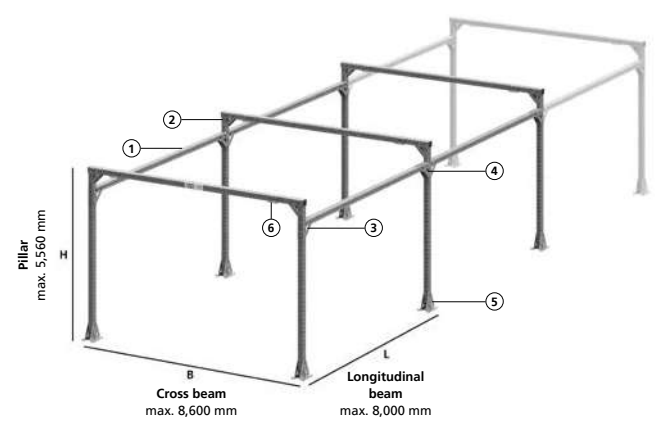

**Modular crane gantry KBG-G**  
Maximum lift capacity approx. 500 kg (incl. lifting device)

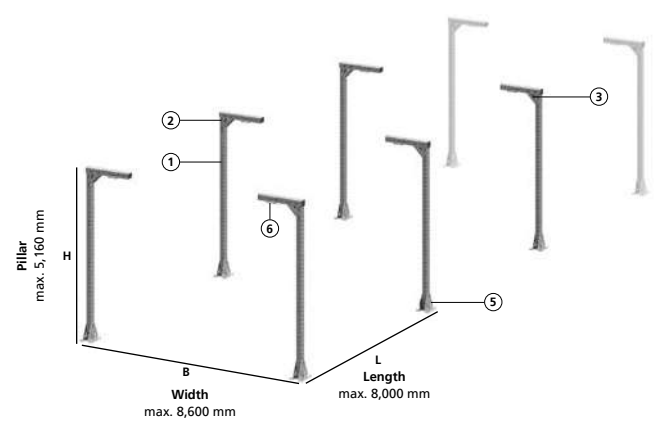

**Modular cantilever arm KBG-C**  
Maximum lift capacity 85 kg

# Crane Systems

## Crane Solutions for Special Applications



### Modular flat jib for particularly low ceilings

- Reduction in the overall height due to flat jib
- Modular jib length up to 5,000 mm
- For loads weighing up to 110 kg



### Articulated-arm jib to move around obstacles

- Easy circumvention of obstacles such as pillars in production halls or machines thanks to the jib with additional joint
- Large usable ceiling height and avoidance of interference contours thanks to integrated vacuum line
- For loads weighing up to 85 kg
- Jib length of 3,000 mm and 4,000 mm



### Telescopic jib for confined working areas

- Jib lengths from 2,000 to 3,000 mm, 3,000 to 4,000 mm and 4,000 to 5,000 mm
- For loads weighing up to 85 kg

## Selected Accessories



### Conductor line SCL

- Provides electricity to all the devices carried along with the crane
- Avoids interference contours



### Cable carrier V-Chain

- Accommodates the hose package of the vacuum supply
- Saves additional space in low room heights



### Swivel angle limiter

- Limit stop for individual adjustment of the swivel range
- The limit for each swivel side is 0° to 120°



### Swivel angle limiter with process monitoring

- Integration of a position dependent machine and process release
- The limit for each swivel side is 0° to 100

# Chain Hoists

Powerful and durable for loads up to 2,500 kg



Schmalz chain hoist SCH

## APPLICATION

- Durable chain hoist with standard limit switches and phosphate-coated, case-hardened steel profile chain
- High-quality pressure-cast aluminum housing with molded cooling fins
- Plug & play connector, the chain hoist arrives ready to use
- Gearboxes with helical gearing make them responsive
- The control voltage of 42 V and the emergency-stop function ensure extremely safe operation
- Robust operator element can be put on the operator handle of the VacuMaster
- CSA certified (USA/Canada)
- Standard lifting height of 3,000 mm, optional variable chain length
- Optional frequency control for sensitive positioning
- CSA certified (USA / Canada)

## PRODUCT HIGHLIGHTS



### Robust housing

- High-quality pressure-cast aluminum housing
- Optimal heat transmission thanks to molded cooling fins



### Plug & play electrical connections

- Plug & play connections for all power connections
- Easy mounting without special tools
- Encoding to prevent faulty connections



### Ergonomic controls

- Comes with strain relief for cables and emergency stop as standard
- Available in different lengths and with two or four control buttons



### Guided chain

- No jamming thanks to two-part guide
- Wear-resistant chainsprocket made from hardened steel
- Longer service life due to phosphated profile steel chain



### Double clutch

- Optimal protection thanks to dual principle of operation
- Easy to service
- Precise and easily adjustable (special tool required)



### Maintenance free brake

- Maximum safety thanks to the brake being positioned behind the sliding clutch
- Maintenance free, modern DC magnetic brake



### Robust motor for extreme application conditions

- Two-phase pole changing drive or with frequency inverter for infinitely variable speed control
- Very smooth running thanks to helical gearing
- Wear free thanks to permanent lubrication of the gearbox



### Standard gear limit switch

- Easy adjustment of the lifting height
- High repeatability for exact positioning of the load

- ▶ System consultants in the field are happy to advise you on-site
- ▼ Experienced service technicians can perform the entire installation upon request

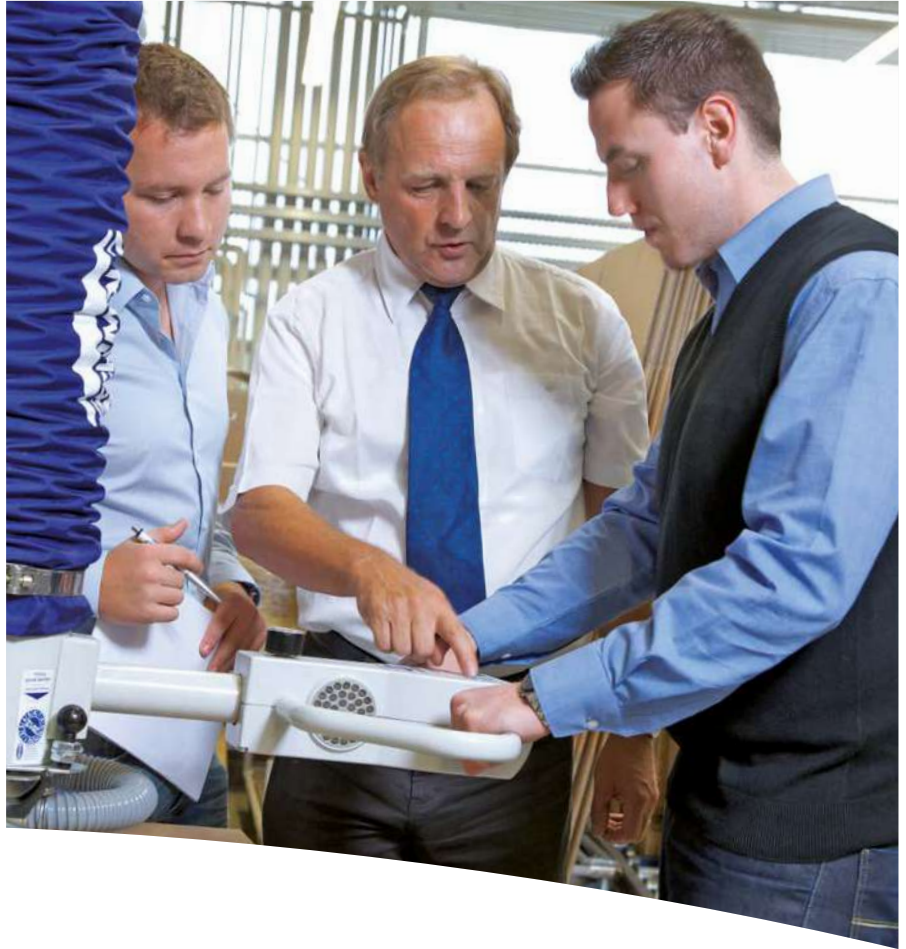

## *Your Project in Good Hands*

With a vacuum handling system from Schmalz, you're choosing more than just a product. We help you find a solution that allows you to work more quickly, more ergonomically, and more efficiently. Our expertise in designing and constructing systems is a result of our years of experience and the comprehensive knowledge of our employees.

# Decide

By Deciding on Schmalz, You're Choosing ...

## Maximum Safety and Reliability

Safety for the operator and process reliability are our main priorities when developing handling systems. All Schmalz products meet or surpass the currently applicable European and international safety standards:

- Consistent observation of safety factors and compliance with safety regulations
- Safe operation with warning and protective systems
- Deliberated operating concept to prevent errors during operation
- High-quality products that are "Made in Germany"
- Comprehensive service package



Annual UVV inspection by Schmalz service technicians

## Working Ergonomically

Musculoskeletal disorders are the most often-cited reason for absence and sick leave from work. One cause of these disorders is lifting and carrying loads during the workday. Even when handling lighter loads, employees often move several tons per shift. For this reason, experts recommend using lifting aids for lifting and carrying even lighter loads. Vacuum handling systems from Schmalz are the perfect tools for lifting and carrying both light and heavy loads. The ergonomic working posture when using these tools is gentle on the spine and the muscles of the back, minimizing the risk of absences due to employee injuries.

Age range	Physically Reasonable Loads			
	Occasional lifting and carrying (no more than 1x per hour)		More frequent lifting and carrying (more than 2x per hour)	
	Women	Men	Women	Men
15 – 18 years old	15 kg	35 kg	10 kg	20 kg
19 – 45 years old	15 kg	55 kg	10 kg	30 kg
> 45 years old	15 kg	45 kg	10 kg	25 kg

Recommendation by the German Federal Ministry of Labour and Social Affairs for implementing the European Directive 90/269/EWG

## Increased Productivity

Vacuum handling systems from Schmalz make your working processes not only more ergonomic, but also more productive:

- Handling speeds at a consistently high level
- Reduced work-related strain increases employee motivation
- Unproductive downtimes, such as during machine loading, are reduced
- Gentle handling minimizes waste

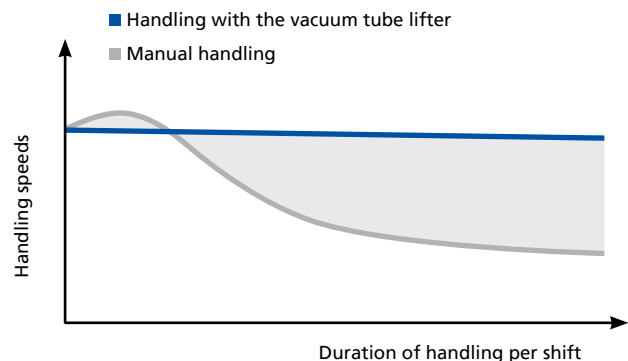



Comparison of handling speeds between handling with the vacuum tube lifter and manual handling

# Select

## Jumbo or VacuMaster?

You can select which handling system is the ideal solution for your application based on the following characteristics.

### YOUR APPLICATION

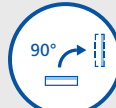
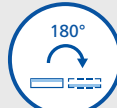
	Max. lift capacity 300 kg		2,000 kg		
Workpiece	Mainly porous and permeable e.g. cardboard boxes, bags and wooden boards		Mainly smooth and airtight e.g. metal plates and glass sheets		
Workpiece format	Max. 4,000 mm x 2,000 mm		Max. 8,000 mm x 2,000 mm		
Type of handling	Horizontal  MAX. 300 KG	90° swiveling  MAX. 120 KG	Horizontal  MAX. 2000 KG	90° swiveling  MAX. 1000 KG	180° turning  MAX. 250 KG
Lifting cycles per hour	up to ~ 500 picks/h		up to ~ 100 picks/h		



### PRODUCT RECOMMENDATION

	Vacuum tube lifter Jumbo	Vacuum lifting device VacuMaster
Application	Move goods weighing up to 300 kg quickly and frequently	Move heavy loads weighing up to 2,000 kg ergonomically and securely
Functions	Vacuum-generated holding force and lifting force	Vacuum-generated holding force, lifting force generated by chain hoist
Product information	Page 12	Page 28

Your Schmalz system consultant would be happy to help you select the right system to fit your requirements. Contact us and benefit from our expertise and years of experience in the field of vacuum handling technology:  
[WWW.SCHMALZ.COM/SALESNETWORK](http://WWW.SCHMALZ.COM/SALESNETWORK)

## Design and Function

### VACUUM TUBE LIFTER JUMBO

The vacuum tube lifter Jumbo consists of a vacuum generator, a lifting unit, an operating unit and vacuum gripper. The Jumbo only uses vacuum to raise and lower loads.

#### Picking up and Lifting the Load

- The vacuum generator (pump, blower or ejector) generates a vacuum in the system by continually evacuating air.
- The difference between the negative pressure and the ambient pressure draws the workpiece to the vacuum gripper. This is generally called "picking up" the workpiece.
- Once the workpiece has been picked up, the flow rate causes the lift tube to contract. The workpiece is then lifted.

#### Lowering and Releasing the Load

- Operating the control element feeds atmospheric air into the system ("venting"). The vacuum is reduced.
- This causes the lift tube to expand and the load is lowered. The lifting height can be precisely controlled by controlling the amount of atmospheric air that is fed into the system. To release the load, the vacuum is completely eliminated through maximum venting via the operator handle.

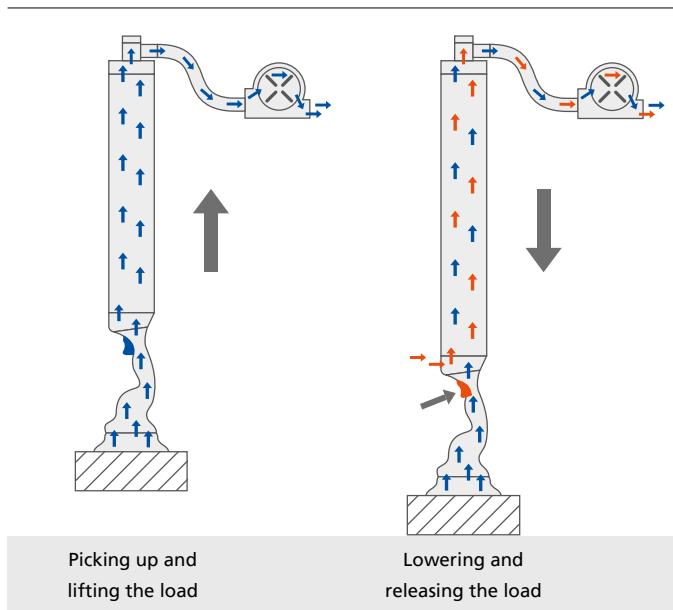

### VACUUM LIFTING DEVICE VACUMASTER

The vacuum lifting device VacuMaster consists of a vacuum generator, load beam with vacuum reservoir and vacuum distributor, an operator handle and suction plates. The vacuum holds the workpiece and a chain hoist is used to lift the workpiece.

#### Picking up and Lifting the Load

- The vacuum generator (pump or ejector) generates a vacuum first in the vacuum reservoir and then in the vacuum distributor by evacuating the air.
- The difference between the negative pressure and the ambient pressure draws the workpiece to the suction plates when the device is placed onto the workpiece. This is generally called "picking up" the workpiece.

#### Lowering and Releasing the Load

- The lifting device with the load that has been picked up is moved up and down by controlling the chain hoist.
- To release the load, the vacuum in the distributor is eliminated through atmospheric venting (activating the valve). The vacuum reservoir remains filled for the next lifting process.

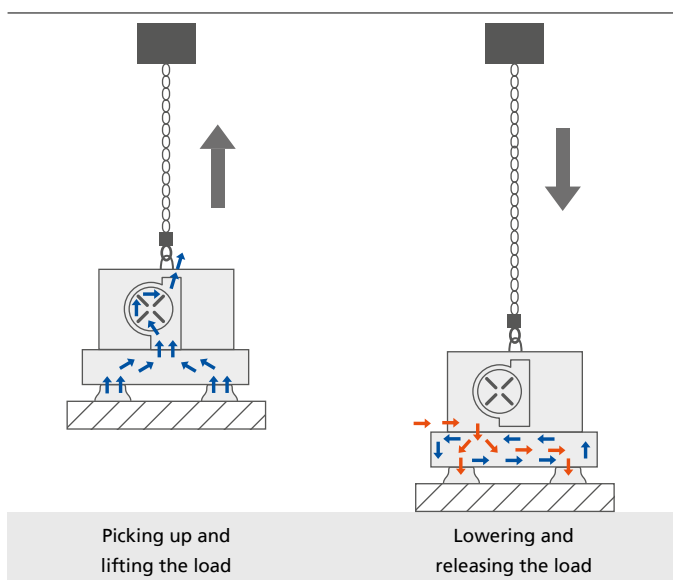

# Design

## Important Information for Designing Your System

When designing the perfect handling solution, there are a large number of deciding factors at play. Using the following questions, you can prepare yourself for the design discussion with your Schmalz system consultant.

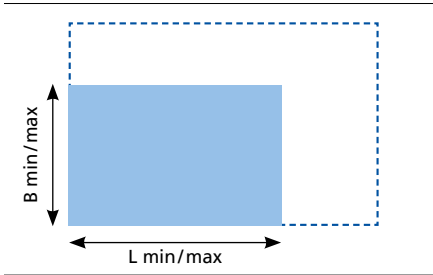

### 1. WORKPIECE

**What are the dimensions of your workpiece [mm]?**

Minimum \_\_\_\_\_

Maximum \_\_\_\_\_

**How thick is the workpiece [mm]?**

Minimum \_\_\_\_\_

Maximum \_\_\_\_\_

**How much does the workpiece weigh [kg]?**

Minimum \_\_\_\_\_

Maximum \_\_\_\_\_

**What is the workpiece material and what are the properties of this material (surface, porosity, etc.)?**

Material \_\_\_\_\_

Airtight

Smooth

Porous

Rough/textured

**Are there sample workpieces available at the location?**

Yes

No

With no airtight workpieces we recommend the implementation of lifting tests.

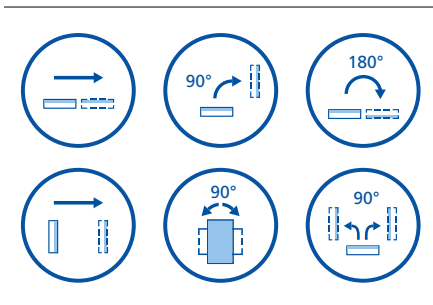

### 2. HANDLING TASK

**What is the workpiece's starting position?**

Horizontal

Vertical

**How will the workpiece be handled?**

Placed horizontally

Swiveled by 90°

Placed vertically

Rotated by 90°

Turned by 180°

**What are the minimum and maximum stack heights [mm]?**

Consider e.g. building columns in production areas, roof girders or cable bridges

Minimum \_\_\_\_\_

Maximum \_\_\_\_\_

**How frequently must workpieces be lifted?**

Picks per hour \_\_\_\_\_

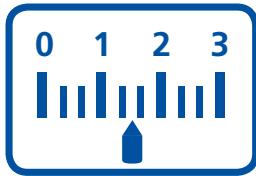

### 3. POWER SUPPLY

**What kind of power supply is available?**

Line voltage (V/Hz) \_\_\_\_\_

Compressed air (bar) \_\_\_\_\_

Standard line voltage for devices with a vacuum blower or vacuum pump:  
400 V 50 Hz (other voltage or frequency ranges available on request). Optimal  
input pressure (flow pressure) for devices with a vacuum ejector: 5.5 to 6 bar.

---

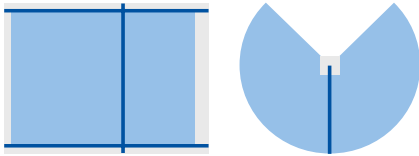

### 4. WORKING AREA

**How large is the working area that needs to be covered [mm]?**

LxB \_\_\_\_\_ or radius \_\_\_\_\_

**How high are the ceilings [mm]?**

\_\_\_\_\_

**What obstacles need to be taken into account?**

e.g. building columns in production areas, roof girders, pipes, light fixtures or  
cable bridges

---

**Which crane system or which kind of mounting might be used?**

Crane system

Jib crane

Ceiling mounting

Floor mounting (column)

Portal mounting

Wall mounting

Required concrete quality for anchoring a crane: at least B25 or C25/235

Required concrete thickness: at least 200 mm for edge distance at least 100 mm

Required concrete thickness: at least 130 mm for edge distance at least 200 mm

---

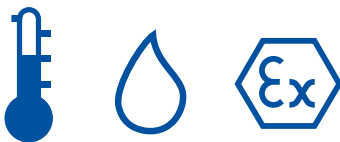

### 5. ADDITIONAL REQUIREMENTS

**What are the additional environmental requirements?**

Special environmental requirements necessitate special product solutions,  
for example:

Extreme temperatures (heat, deep freeze sector)

Particularly high humidity

Clean room conditions

Heavy contamination

Avoidance of marks

Explosion protection zone

Additional:

\_\_\_\_\_  
\_\_\_\_\_  
\_\_\_\_\_

# Schmalz Services

## Our Worry-free Service Offering

### Digital Product File

The free Schmalz ControlRoom app gives you quick and easy access to device-specific information. The identification tag on the device contains the serial number and can be read either via QR code or NFC using a smartphone. The one-time registration in the Schmalz ControlRoom app grants access to additional information such as service dates, operating instructions, spare and wear parts lists and much more.



### Consultation

Highly qualified system consultants support you from the planning stage, through design and installation, to the start of operations of your handling solution and beyond.



### Installation and commissioning

Upon request, our experienced service technicians will perform the complete installation, including electrical connection by a qualified electrician. The installation is completed when the system is put into operation.



### Instruction

We are happy to train you and your employees on site to get the most out of your new handling system.



### Thorough examination according to local regulations

Legal regulations require that vacuum lifters and cranes be inspected regularly by an expert. This ensures the safety and uptime of your equipment.



### Service agreements

We offer special service agreements for our vacuum lifters in order to avoid possible repairs. Preventive maintenance ensures long-term availability of the vacuum lifter and avoids downtime.



### Spare and wear parts

We supply original spare and wear parts of the highest quality quickly and reliably when required. Order easily and conveniently in our online shop.



### Repair

You have a faulty device or component that can be repaired: Please return defective pumps, valves, and other components using our return shipping label.



### On-site service

The faulty product is an integral part of your process: In this case, you need fast on-site help. Our service technicians will fix the problem immediately and reliably on site.

# Contact

## Own Subsidiaries and Trade Partners in More Than 80 Countries

Our sales network of local field representatives, international subsidiaries and trade partners ensures quick and competent information and advice.

### AUSTRALIA

Schmalz Australia Pty. Ltd.  
25 Turbo Drive  
Bayswater North VIC 3153  
T: +61 3 9215 8800  
schmalz@schmalz.com.au

### CANADA

Schmalz Vacuum Technology Ltd.  
14-2900 Argentia Road  
ON L5N 7X9 Mississauga  
Ontario  
T: +1 905 569 9520  
schmalz@schmalz.ca

### INDIA

Schmalz India Pvt. Ltd.  
EL – 38 'J' Block MIDC  
Bhosari  
411026 Pune  
T: +91 20 4072 5500  
schmalz@schmalz.co.in

### UNITED KINGDOM

Schmalz UK Limited  
Unit 2  
Woodrow Business Centre  
Woodrow Way, Irlam  
Manchester M44 6NN  
T: +44 0161 266 1115  
schmalz@schmalz.co.uk

### UNITED STATES

Schmalz Inc.  
5850 Oak Forest Drive  
Raleigh, NC 27616  
T: +1 919 713 0880  
schmalz.us@schmalz.com

### WORLDWIDE

**Headquarters in Germany**  
J. Schmalz GmbH  
Johannes-Schmalz-Str.1  
72293 Glatten  
T: +49 7443 2403-0  
schmalz@schmalz.de

For contact information for our trade partners in 80 countries please visit: [WWW.SCHMALZ.COM/SALESNETWORK](http://WWW.SCHMALZ.COM/SALESNETWORK)

## BINAR HANDLING

Part of the  Group



Quick-Lift Rail for intuitive and ergonomic load movement

## Rope Balancers for Sensitive Motion and Precise Positioning

The Swedish company Binar Handling AB and its subsidiaries are part of the Schmalz Group. Binar Handling's portfolio includes intelligent and ergonomically designed lifting solutions such as rope balancers and manipulators. The Quick-Lift lifting systems are leading in precision and ease of use. A crane arm or rail system supports the handling and creates a flexible and safe working environment. Pneumatic, magnetic, mechanical or vacuum grippers can be used for a wide range of loads and customer requirements.

[www.binarhandling.com](http://www.binarhandling.com)

## The Schmalz Group – Worldwide On Site

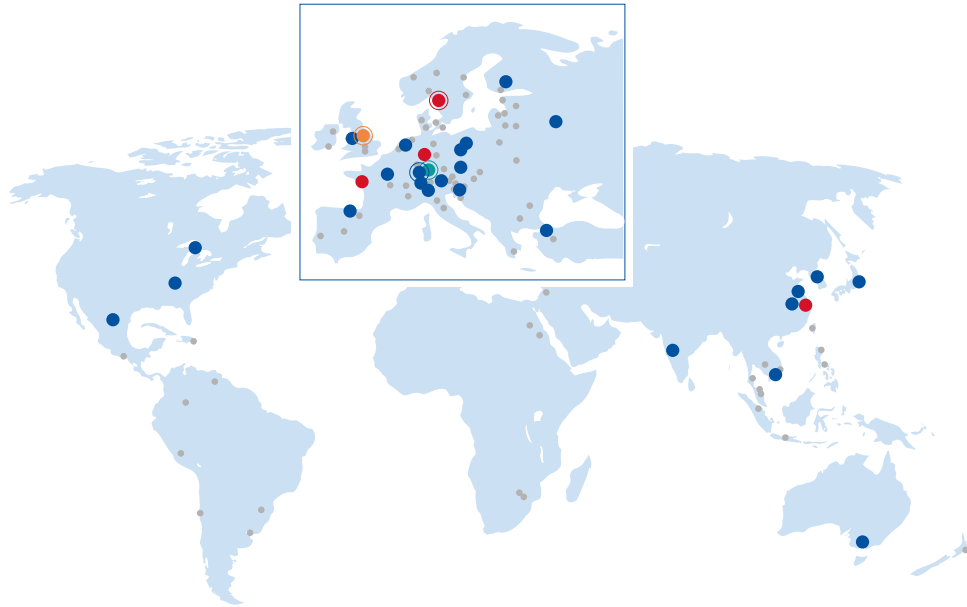

● Germany – Glatten

● International companies:

Australia – Melbourne  
 Austria – Pasching  
 Benelux – Hengelo (NL)  
 Canada – Mississauga  
 China – Shanghai  
 China – Taicang  
 Czech Republic – Hranice  
 Finland – Vantaa  
 France – Champs-sur-Marne  
 India – Pune  
 Italy – Galliate  
 Japan – Yokohama

● Sales partners

Mexico – Querétaro  
 Poland – Bydgoszcz  
 Poland – Poznan  
 Russia – Moscow  
 South Korea – Anyang  
 Slovenia – Vrhnik  
 Spain – Erandio  
 Switzerland – Nürensdorf  
 Turkey – Istanbul  
 United Kingdom – Manchester  
 USA – Raleigh  
 Vietnam – Ho Chi Minh City

**BINAR HANDLING**

● Sweden – Trollhättan

● International companies:

China – Shanghai  
 France – La Haie-Fouassière  
 Germany – Staufenberg

 Palamatic

● United Kingdom – Chesterfield

 GPS  
GESELLSCHAFT FÜR  
 PRODUKTIONSTECHNIK

● Germany – Stuttgart

### Vacuum Automation

[WWW.SCHMALZ.COM/AUTOMATION](http://WWW.SCHMALZ.COM/AUTOMATION)

### Handling Systems

[WWW.SCHMALZ.COM/HANDLING-SYSTEMS](http://WWW.SCHMALZ.COM/HANDLING-SYSTEMS)

**J. Schmalz GmbH**

Johannes-Schmalz-Str. 1  
 72293 Glatten, Germany  
 T: +49 7443 2403-0  
 schmalz@schmalz.de  
 WWW.SCHMALZ.COM



schmalz.vacuumtechnology



schmalz\_group



schmalzmediacenter



schmalz



j-schmalzgmbh



schmalz\_de